

NUUR

AUTOMATIC BARRIER

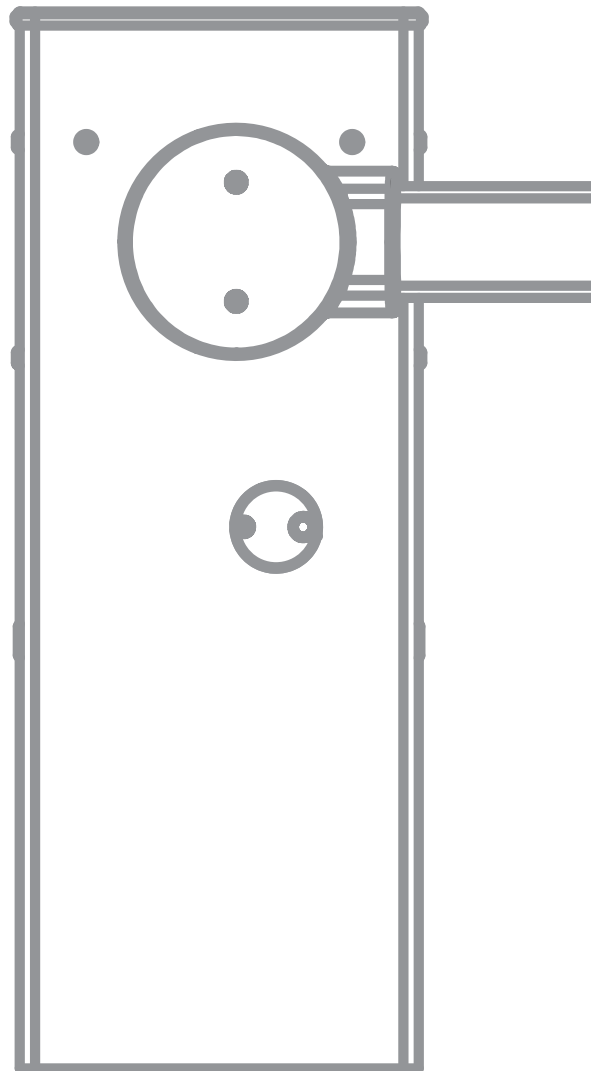

INDEX

1 - GENERAL SAFETY WARNINGS AND PRECAUTIONS	46
1.1 - GENERAL WARNINGS.....	46
1.2 - INSTALLATION WARNINGS	46
1.3 - DISPOSAL.....	46
1.4 - EU DECLARATION OF CONFORMITY.....	47
2 - PRODUCT DESCRIPTION AND INTENDED USE	47
2.1 - TECHNICAL CHARACTERISTICS.....	47
2.2 - LIST OF CONSTITUENT PARTS	48
3 - INSTALLATION	48
3.1 - PRE-INSTALLATION CHECKS.....	48
3.2 - PRODUCT USAGE LIMITS	48
3.3 - PRODUCT IDENTIFICATION AND OVERALL DIMENSIONS.....	49
3.4 - RECEIPT OF THE PRODUCT	49
3.5 PRE-INSTALLATION WORKS	50
3.6 - ADJUSTING THE BOOM GATE	51
3.7 - INSTALLING THE GEARMOTOR	53
3.8 - INSTALLING THE BOOM.....	54
3.9 - ADJUSTING THE MECHANICAL LIMIT SWITCHES.....	55
3.10 - BOOM BALANCING.....	56
3.11 - MANUALLY UNLOCKING AND LOCKING THE GEARMOTOR	56
4 - ELECTRICAL CONNECTIONS	56
4.1 - PRELIMINARY CHECKS.....	56
5 - CONTROL UNIT	57
5.1 - POWER SUPPLY	57
5.2 - ECO-LOGIC POWER SUPPLY.....	57
5.3 - INGRESSI DI ATTIVAZIONE	58
5.4 - STOP	58
5.5 - PHOTOCELLS.....	58
5.6 - SAFETY RIBBONS	59
5.7 - COURTESY LIGHT	59
5.8 - LOW VOLTAGE LIGHT OUTPUT.....	59
5.9 - ANTENNA	59
5.10 - HOLDING MAGNET	59
5.11 - MAGNETIC COIL OR PRESENCE SENSOR.....	59
6 - ELECTRICAL CONNECTIONS	60
7 - PANNELLO DI CONTROLLO	62
7.1 - DISPLAY.....	62
7.2 - USE OF THE KEYS FOR PROGRAMMING.....	62
8 - ACCESSING THE CONTROL UNIT SETTINGS	63
9 - LOADING THE DEFAULT PARAMETERS	63
10 - QUICK CONFIGURATION	64
11 - EMERGENCY DEAD MAN OPERATION	64
12 - READING THE COUNTER OF THE CYCLES AND EVENTS MEMORY	64
13 - PROGRAMMING THE CONTROL UNIT	65
14 - TESTING AND COMMISSIONING	72
14.1 - TESTING	72
14.2 - COMMISSIONING	73
15 - FURTHER INFORMATION (Accessories)	74
15.1 - PLUG IN RECEIVER	74
15.2 - CONNECTING AND INSTALLING THE BACKUP BATTERY	74
15.3 - BOOM LIGHTS CONNECTION (OPTIONAL ACCESSORY).....	74
15.4 - PHOTOCELLS.....	75
16 - TIMER SETTING	76
16.1 - CLOCK SETTING	76
16.2 - TIMINGS SETTING	76
16.3 - SUPSENDING TIMERS.....	76
17 - TRAFFIC LIGHT FUNCTION	80
18 - OPERATION DEFECTS	83
INSTRUCTIONS AND WARNINGS FOR THE USER	85
MAINTENANCE SCHEDULE (to be handed to the end user)	87

1 - GENERAL SAFETY WARNINGS AND PRECAUTIONS

1.1 - GENERAL WARNINGS

 **WARNING! Important safety instructions. Observe all the instructions as improper installation may cause serious damages.**

 **WARNING! Important safety instructions. It is important to comply with these instructions to ensure personal safety. Store these instructions carefully.**

 **According to the latest European legislation, an automated device must be constructed in conformity to the harmonised rules specified in the current Machinery Directive, which allow for declaring the presumed conformity of the automation. Consequently, all the operations for connecting the product to the mains electricity, its commissioning and maintenance must be carried out exclusively by a qualified and expert technician.**

 **In order to avoid any danger from inadvertent resetting of the thermal cut-off device, this appliance must not be powered through an external switching device, such as a timer, or connected to a supply that is regularly powered or switched off by the circuit.**

WARNING! Please abide by the following warnings:

- Before commencing the installation, check the “Product technical specifications”, in particular whether this product is suitable for automating your guided part. Should it not be suitable, do NOT proceed with the installation.
- The product cannot be used before it has been commissioned as specified in the “Testing and commissioning” chapter.
- Before proceeding with the product’s installation, check that all the materials are in good working order and suited to the intended applications.
- The product is not intended for use by persons (including children) with reduced physical, sensory or mental capacities, nor by anyone lacking sufficient experience or familiarity with the product.
- Children must not play with the appliance.
- Do not allow children to play with the product’s control devices. Keep the remote controls out of reach of children.
- The system’s power supply network must include a disconnection device (not supplied) with a contact opening gap permitting complete disconnection under the conditions envisaged by Overvoltage Category III.
- During the installation process, handle the product with care by avoiding crushing, impacts, falls or contact with liquids of any kind. Do not place the product near sources of heat nor expose it to open flames. All these actions can damage the product and cause it to malfunction, or lead to dangerous situations. Should this occur, immediately suspend the installation process and contact the Technical Assistance Service.
- The manufacturer declines all liability for damages to property, objects or people resulting from failure to observe the assembly instructions. In such cases, the warranty for material defects shall not apply.
- The weighted sound pressure level of the emission A is lower than 70 dB(A).
- Cleaning and maintenance reserved for the user must not be carried out by unsupervised children.
- Before intervening on the system (maintenance, cleaning), always disconnect the product from the mains power supply and from any batteries.

- Inspect the system frequently, in particular the cables, springs and supports to detect any imbalances and signs of wear or damage. Do not use the product if it needs to be repaired or adjusted, because defective installation or incorrect balancing of the automation can lead to injuries.
- The packing materials of the product must be disposed of in compliance with local regulations.
- Keep persons away from the gate when it is manoeuvred using the control elements.
- When operating the gate, keep an eye on the automated mechanism and keep all bystanders at a safe distance until the movement has been completed.
- Do not operate the product if anyone is working nearby; disconnect its power supply before permitting such work to be done.

1.2 - INSTALLATION WARNINGS

- Prior to installing the drive motor, check that all mechanical components are in good working order and properly balanced, and that the automation can be manoeuvred correctly.
- Make sure that the control elements are kept far from moving parts but nonetheless directly within sight. Unless a selector is used, the control elements must be installed at least 1.5 m above the ground and must not be accessible.
- If the opening movement is controlled by a fire-sensing system, make sure that any windows larger than 200 mm are closed using the control elements.
- Prevent and avoid any form of entrapment between the moving and fixed parts during the manoeuvres.
- Permanently affix the label concerning the manual manoeuvre near its actuating element.
- After installing the drive motor, make sure that the mechanism, protective system and all manual manoeuvres function properly.



1.3 - DISPOSAL

As for the installation operations, even at the end of this product’s life span, the dismantling operations must be carried out by qualified experts.

This product is made up of various types of materials: some can be recycled while others need to be disposed of. Find out about the recycling or disposal systems envisaged by your local regulations for this product category.

Important! – Parts of the product could contain pollutants or hazardous substances which, if released into the environment, could cause harmful effects to the environment itself as well as to human health.

As indicated by the symbol opposite, throwing away this product as domestic waste is strictly forbidden. So dispose of it as differentiated waste, in accordance with your local regulations, or return the product to the retailer when you purchase a new equivalent product.

Important! – the local applicable regulations may envisage heavy sanctions in the event of illegal disposal of this product.

1.4 - EU DECLARATION OF CONFORMITY AND DECLARATION OF INCORPORATION OF PARTLY COMPLETED MACHINE

Declaration in accordance with Directives: 2014/35/UE (LVD); 2014/30/UE (EMC); 2006/42/CE (MD) ANNEX II, PART B

The manufacturer V2 S.p.A., headquarters in Corso Principi di Piemonte 65, 12035, Racconigi (CN), Italy

Under its sole responsibility hereby declares that: the partly completed machinery model(s): **NUUR4, NUUR6**

Description: electromechanical actuator for barriers

- is intended to be installed to create a machine according to the provisions of the Directive 2006/42/EC. The machinery must not be put into service until the final machinery into which it has to be incorporated has been declared in conformity with the provisions of the Directive 2006/42/EC (annex II-A).
- is compliant with the applicable essential safety requirements of the following Directives:
 - Machinery Directive 2006/42/EC (annex I, chapter 1)
 - Low Voltage Directive 2014/35/EU
 - Electromagnetic Compatibility Directive 2014/30/EU
 - Directive RoHS3 2015/863/EU

Furthermore, the product complies with the following standards: EN IEC 61000-6-2:2019, EN IEC 61000-6-3:2021 EN 60335-1:2012 + A11:2014 + A13:2017 + A1:2019 + A2:2019 + A14:2019 + A15:2021, EN 62233:2008, EN 60335-2-103:2015

The relevant technical documentation is available at the national authorities' request after justifiable request to: V2 S.p.A. Corso Principi di Piemonte 65, 12035, Racconigi (CN), Italy

The person empowered to draw up the declaration and to provide the technical documentation:

Roberto Rossi

Legal representative of V2 S.p.A.
Racconigi, 01/03/2023



2 - PRODUCT DESCRIPTION AND INTENDED USE

NUUR are electromechanical road barrier mechanisms for residential, public and industrial use, which control the opening and closing of a driveway.

These barriers are equipped with an electromechanical gearmotor with a 24 V motor.

The barriers work on electricity and in case of a power outage (blackout), the boom can be unlocked manually and moved by hand. Alternatively, it is possible to use the back-up battery (model 161261 - optional accessory) which ensures that certain manoeuvres can be carried out in the first few hours of a power outage.

The barriers must be combined with the available booms, individually or in pairs, to reach the desired length. Various optional accessories are available, depending on the chosen boom, as shown in the table.

INSTALLABLE ACCESSORIES			
	NUUR4	NUUR6	
Cubicle			
Boom	4 m	5 m	3+3 m
Rubber	si	si	si
Lights	si	si	si
Jointed boom	si	-	-
Aluminium skirt	2 pz	2 pz	2 pz
Mobile support	1 pz	1 pz	1 pz

Important notes for using the manual:

- throughout this manual, the term "boom gate" refers to the three products "NUUR4" and "NUUR6"
- the accessories mentioned in the manual are optional.

⚠ Any use of the product other than the intended use described is not allowed!

2.1 - TECHNICAL CHARACTERISTICS

	NUUR4	NUUR6
Power supply	230 V~ 50 Hz	
Motor power supply	24 Vdc	
Maximum power	300W	240W
Power in stand-by *	3,5W	3,5W
Opening time	3 ÷ 4 s	5 ÷ 6 s
Operative intermittence	80 % (300 cicli ora max.) > 4s pause between each cycle	80 % (200 cicli ora max.) > 6s pause between each cycle
Maximum load on 24 Vdc attachments	12W on Z1-Z2-Z3 terminals	
	12W on Z4-Z5-Z6 terminals ATTENTION: any consumption of the RGB LEDs and / or traffic lights connected to the optional SYNCLUX module must be subtracted from this load (refer to the SYNCLUX manual)	
Operating temperature	-20 ÷ +55 °C	
Protection degree	IP54	
Weight	44 Kg	52 Kg

* If the **ENERGY SAVING mode is activated (parameter E n. 5R = 5)** the power at rest is **0.4W**.

2.2 - LIST OF CONSTITUENT PARTS

"Figure 1" shows the main parts making up the NUUR.

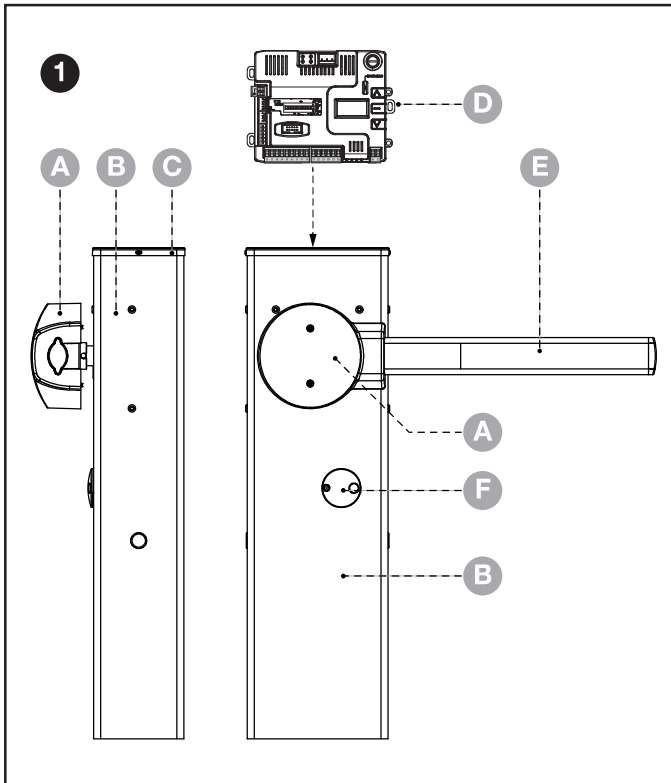

- A Boom support
- B Gearmotor containment box
- C Cover
- D Electronic control and command unit
- E Boom
- F Locking/unlocking key

3 - INSTALLATION

3.1 - PRE-INSTALLATION CHECKS

⚠ The installation must be carried out by qualified personnel in compliance with the current legislation, standards and regulations, and with the instructions provided in this manual.

Before proceeding with the product's installation, it is necessary to:

- check the integrity of the supply
- check that all the materials are in good working order and suited to the intended use
- check whether it is possible to observe the operating limits specified in the paragraph "Product usage limits"
- check that the installation location is compatible with the overall clearance of the product (see "Figure 2")
- check that the surface chosen for installing the boom gate is solid and can ensure stable anchorage
- make sure that the installation area is not subject to flooding; if necessary, the product must be installed appropriately raised above ground level
- check that the space surrounding the boom gate allows for executing the manual manoeuvres easily and safely
- check that there are no obstacles along the boom's path capable of hampering the opening and closing manoeuvres
- check that each device to be installed lies in a position that is protected against the risk of accidental impact.
- verify that the mounting positions of the various devices are protected against impacts and that the mounting surfaces are sufficiently sturdy
- prevent any parts of the automation from being immersed in water or other liquids
- keep the product away from heat sources and open flames and acid, saline or potentially explosive atmospheres; these may damage the product and cause malfunctions or dangerous situations
- connect the control unit to an electricity supply line equipped with a safety earthing system

3.2 - PRODUCT USAGE LIMITS

Before proceeding with the product's installation, it is necessary to:

- check that all the values appearing in the "TECHNICAL SPECIFICATIONS" chapter are compatible with the intended use
- check that all limitations, conditions and warnings appearing in this manual can be fully observed.

3.3 - PRODUCT IDENTIFICATION AND OVERALL DIMENSIONS

The overall dimensions and the label (A), which allows for identifying the product, are shown in "Figure 2".

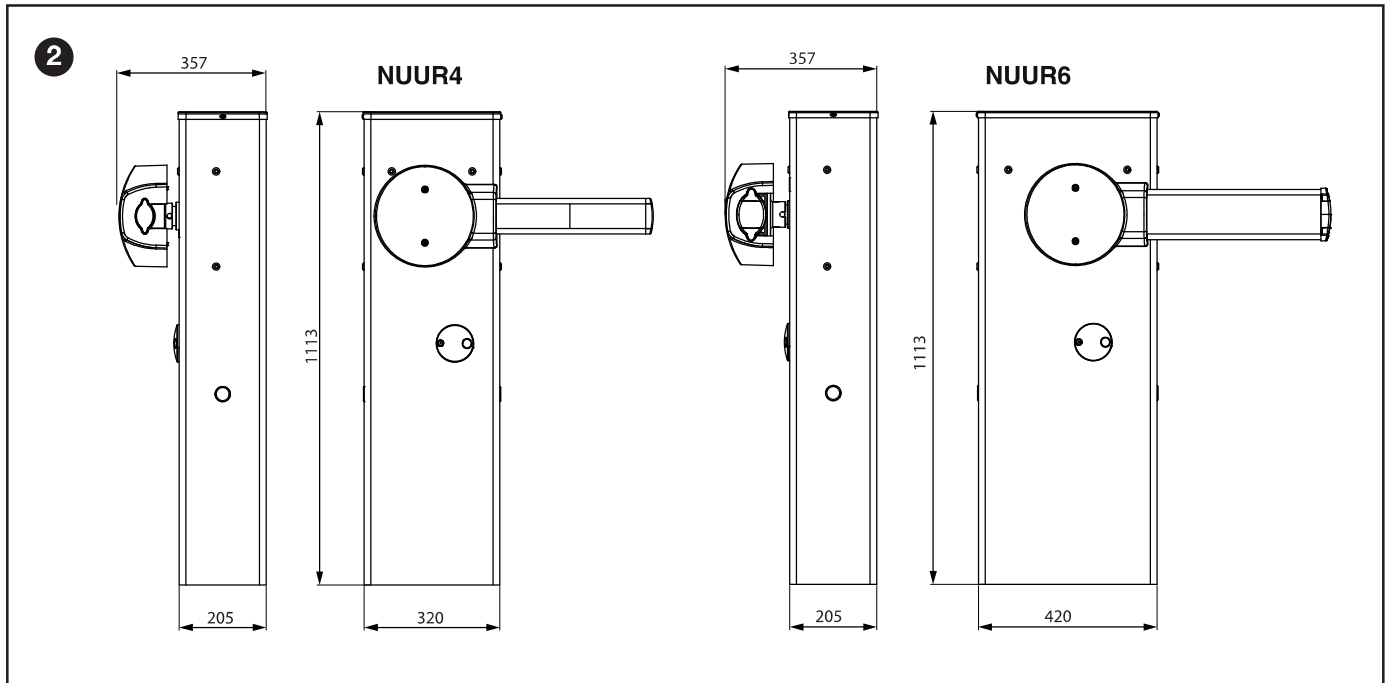

3.4 - RECEIPT OF THE PRODUCT

All the components contained in the product's packaging are illustrated and listed below.

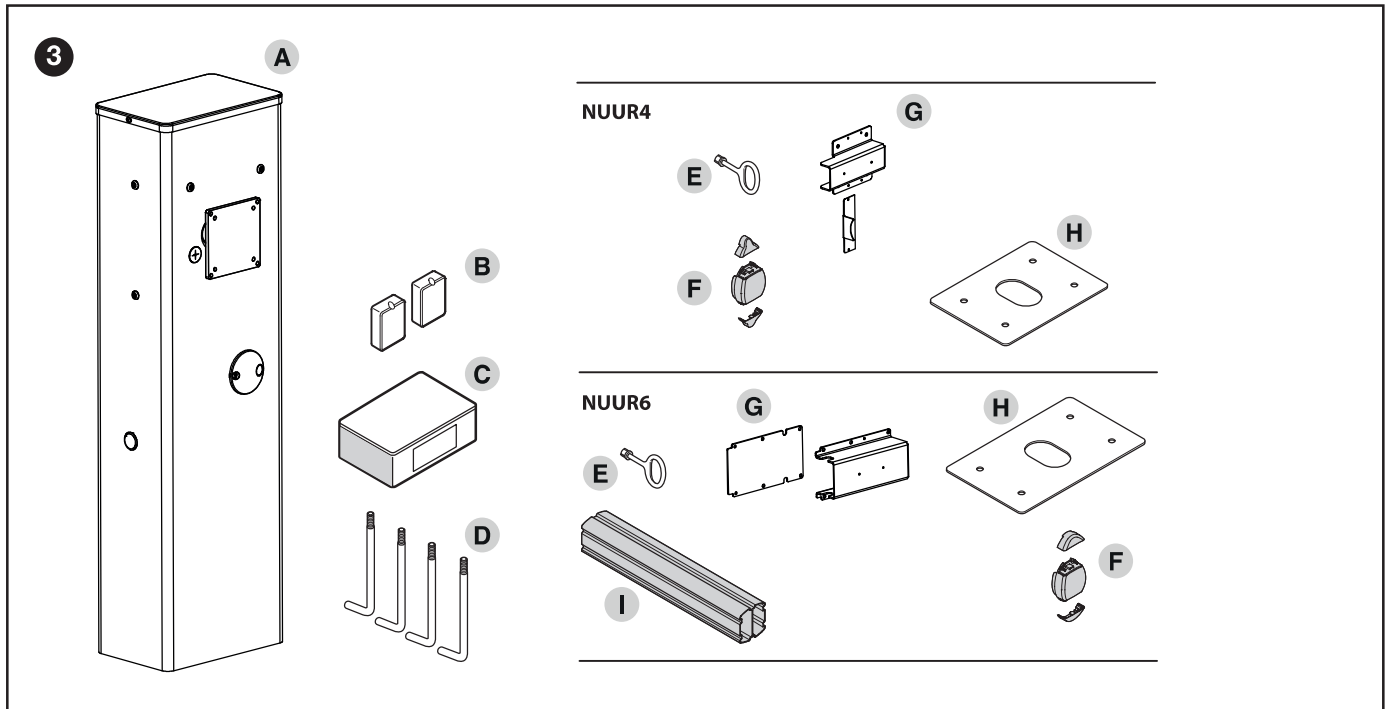

A Boom gate with integrated control unit

B 2 photocell boxes

C Metal hardware (screws, washers, etc.)

D 4 anchor bolts

E Keys for manually locking and unlocking the boom

F Fixed boom cap; 2 connectors for rubber impact protectors

G Boom support

H Foundation plate

I Boom connector (only present on NUUR6)

3.5 PRE-INSTALLATION WORKS

The figure shows an example of an automation system:

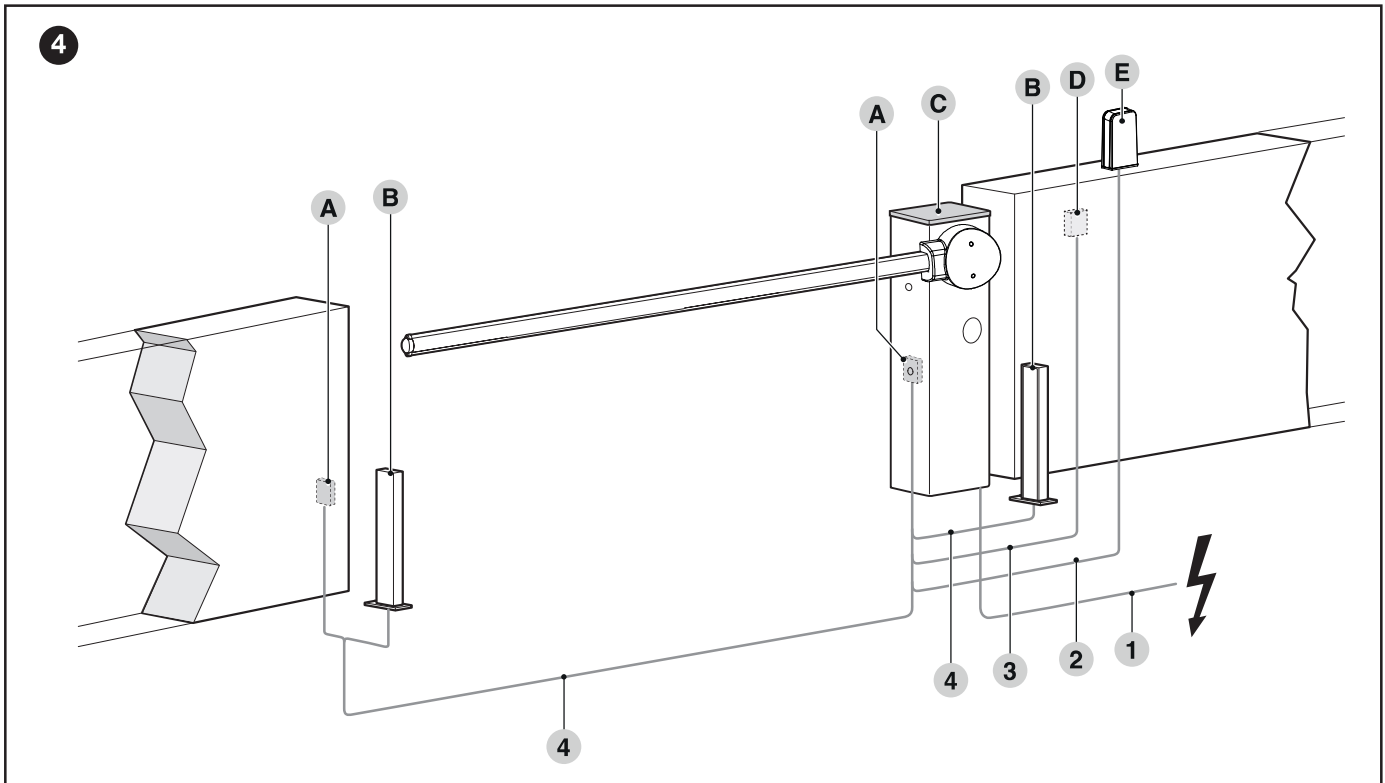

- A Photocells
- B Photocells on column
- C Boom gate cubicle
- D Key selector
- E Warning light

The above-mentioned components are positioned according to a typical standard layout. Using the layout in "Figure 4" as a reference, define the approximate position in which each component of the system will be installed.

TECHNICAL SPECIFICATIONS OF ELECTRICAL CABLES	
Identification no.	Cable characteristics
1	GEARMOTOR POWER SUPPLY cable 1 cable 3 x 1,5 mm ² Maximum length 30 m [note 1]
2	WARNING LIGHT cable [nota 4] 1 cable 2 x 0,5 mm ² Maximum length 30 m
3	KEY SELECTOR cable 2 cables 2 x 0,25 mm ² [nota 3] Maximum length 30 m
4	PHOTOCELL cable 1 cable 2 x 0.25 mm ² (TX) 1 cable 4 x 0.25 mm ² (RX) Maximum length 30 m [note 2]
Altri cavi	OPEN INPUT cable 1 cable 2 x 0.25 mm ² Maximum length 30 m
	CLOSE INPUT cable 2 x 0.25 mm ² Maximum length 30 m
	ANTENNA cable 1 x RG58-type shielded cable Maximum length 15 m; recommended < 5 m
	OPEN BOOM INDICATOR cable [note 4] 1 cable 2 x 0.5 mm ² Maximum length 30 m
	BOOM LIGHTS cable [note 4]

Note 1 If the power supply cable is longer than 30 m, a cable with larger cross-sectional area (3 x 2.5 mm²) must be used and a safety earthing system must be installed near the automation.

Note 2 If the cable is longer than 30 m, up to maximum 40 m, it is necessary to use a cable with a greater cross-sectional area (2 x 1 mm²).

Note 3 These two cables can be replaced by a single 4 x 0.5 mm² cable.

Note 4 Before making the connection, verify that the output is programmed on the basis of the device to be connected (refer to the chapter "PROGRAMMING")..

⚠ The cables used must be suited to the type of environment of the installation site.

⚠ When laying the pipes for routing the electrical cables, take into account that any water deposits in the junction boxes may cause the connection pipes to form condensate inside the control unit, thus damaging the electronic circuits.

⚠ Before proceeding with the installation, prepare the required electrical cables by referring to "Figure 4" and to that stated in the "TECHNICAL SPECIFICATIONS" chapter.

3.6 - ADJUSTING THE BOOM GATE

The boom gate is factory-set in the following way:

- balancing spring fastened to the right, anchored through non-permanent holes
- closing manoeuvre of the boom towards the left (barrier to the RIGHT of the road crossing - parameter $d_{ir} = d_{3C}$ as DEFAULT)

To move the spring attachment, proceed as explained below:

1. remove the upper cover (A) of the boom gate cubicle
2. slide out the rear panel first towards the other and then outwards

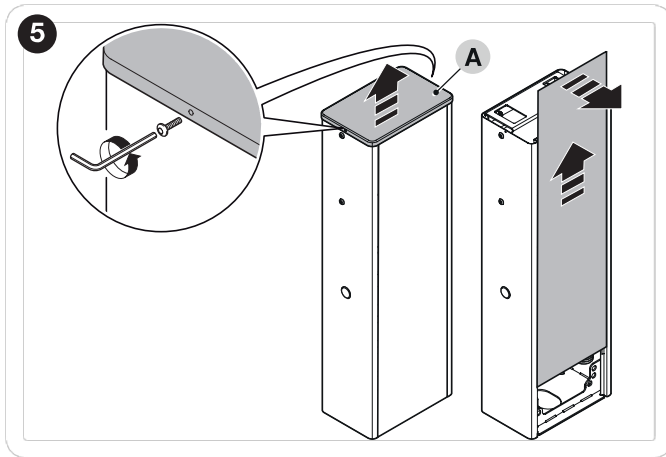

3. loosen the tension of the balancing spring on NUUR4 and NUUR6 by loosening the nut (B)

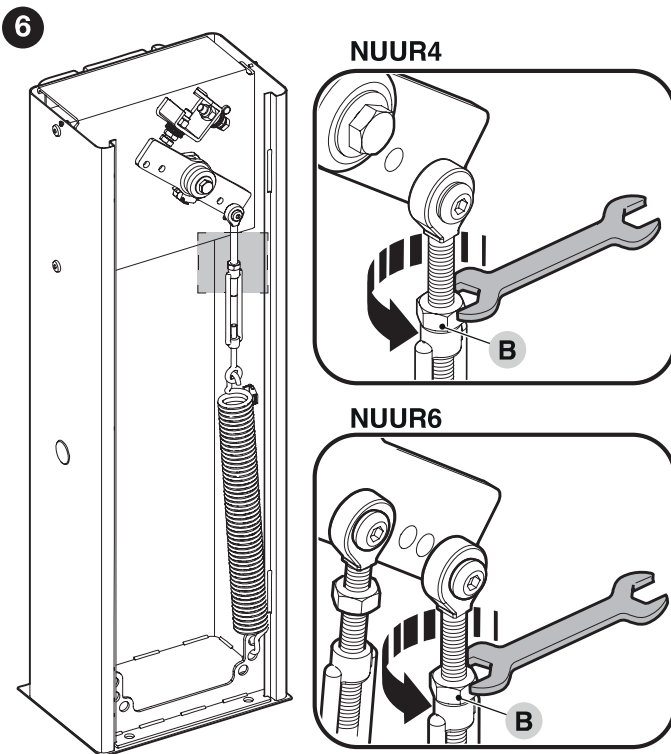

4. loosen the bolt (C) fastening the spring to the balancing lever

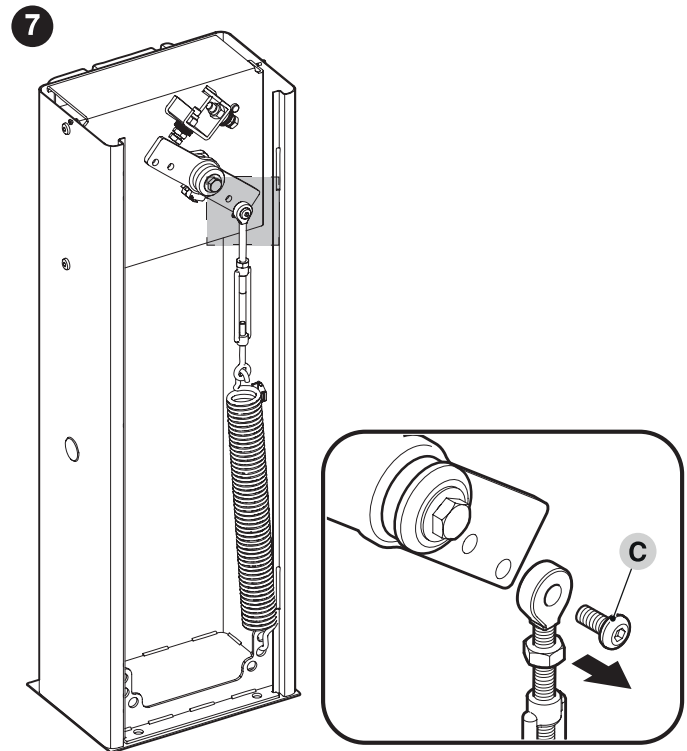

5. remove the balancing spring, by detaching it from the lower plate
6. if the closing direction is the desired one, the balancing spring should be positioned as shown in the diagram

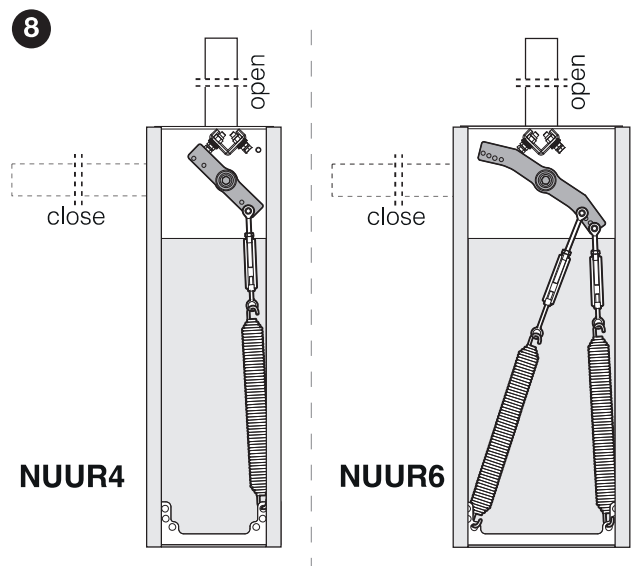

7. to set the closing manoeuvre of the boom towards the right of the barrier mechanism:

- unlock the gearmotor (refer to the “**Manually unlocking and locking the gearmotor**” paragraph) and turn the balancing lever by 90°

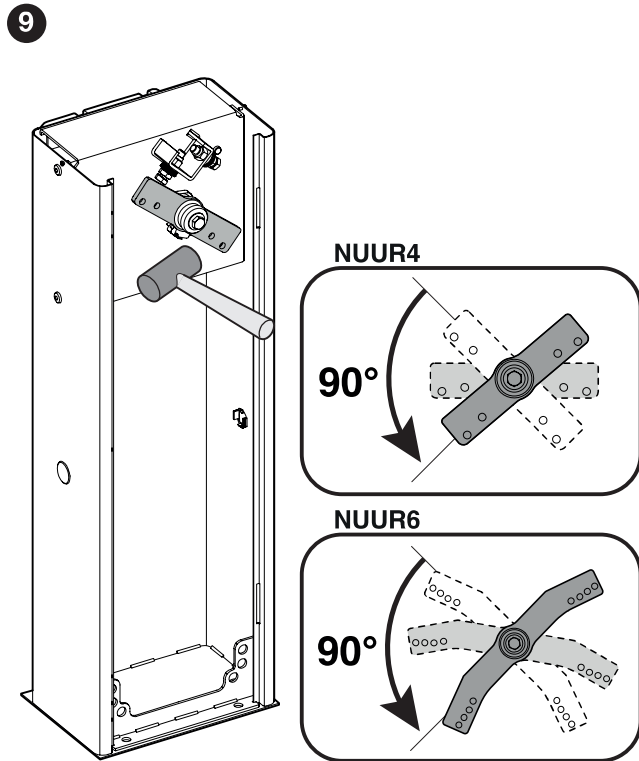

- the balancing spring should be positioned as shown in the diagram

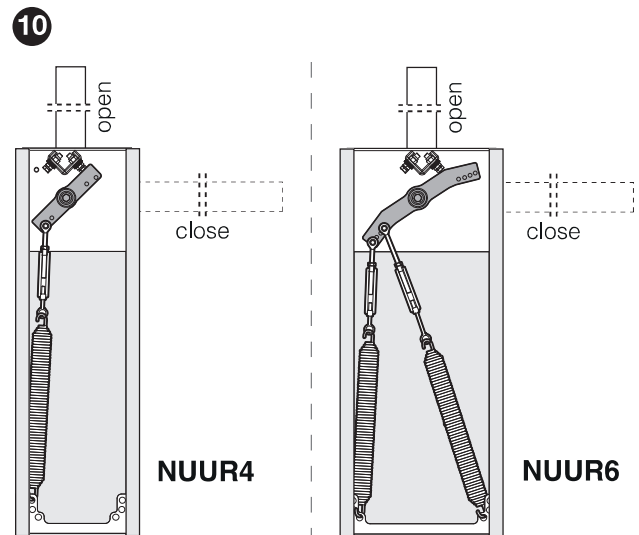

8. secure the spring to the lower plate

9. fasten the spring's eyelet to the balancing lever, tightening the bolt vigorously

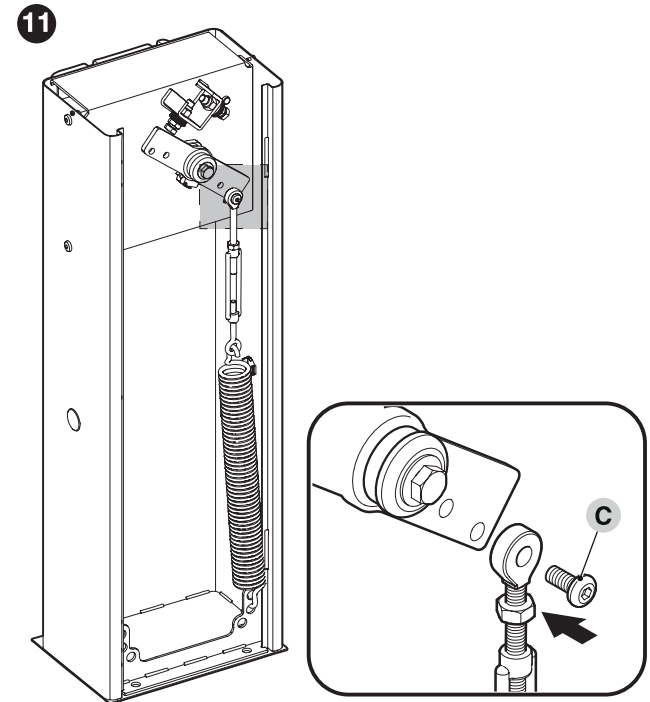

10. close the covers of the gearmotor

11. if the gearmotor was previously unlocked, lock it again

NOTE: if the opening direction of the boom was modified, during the programming phase of the control unit, the parameter must be set $dir = 53C$

3.7 - INSTALLING THE GEARMOTOR

⚠ Incorrect installation may cause serious physical injury to the person working on the system or to its future users. Before starting to assemble the automation, complete the preliminary checks described in the “Preinstallation checks” and “Product usage limits” paragraphs.

If there is a support surface:

1. remove the upper cover (A) of the boom gate cubicle
2. slide out the rear panel first towards the other and then outwards

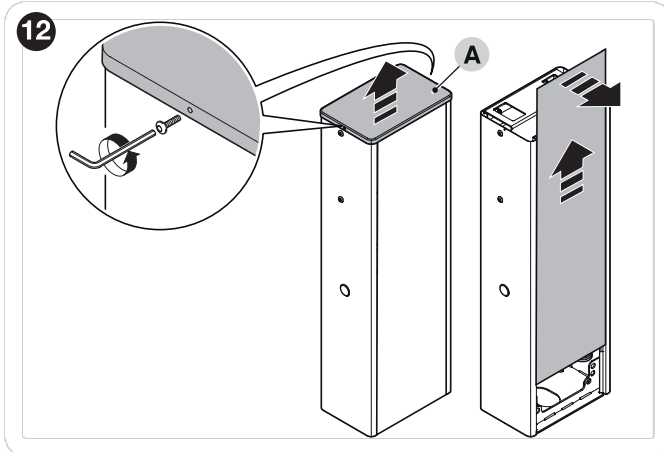

3. place the cubicle on the anchoring surface and mark the points corresponding to the slots

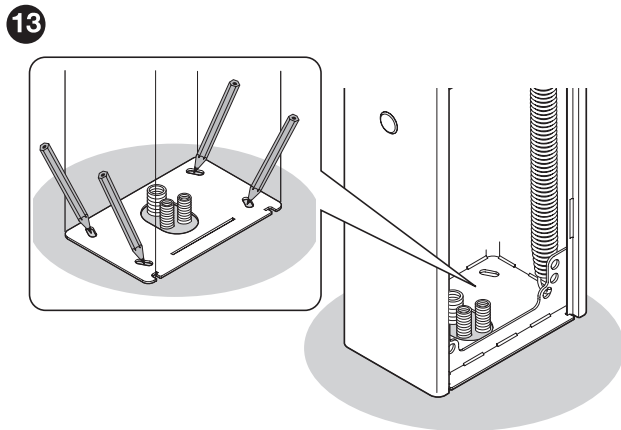

4. move the cubicle and drill the surface through the marked points
5. insert 4 expansion bolts (not supplied)
6. arrange the cubicle properly and secure it with the appropriate nuts and washers (not supplied).

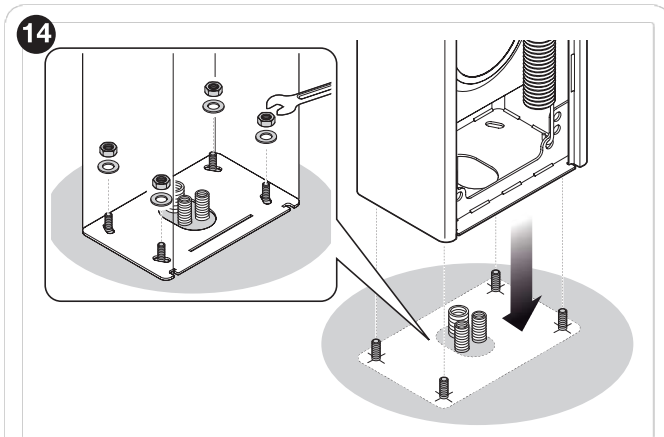

If there is no support surface:

1. dig the hole to insert the foundation plate

NOTE: The anchoring surface must be completely flat and smooth. If the surface is made of concrete, the latter must be at least 0,15 m thick and must be suitably reinforced with iron cages. The concrete must have a volume above 0,2 m³ (a 0,25 m thickness corresponds to 0,8 m², that is, equal to a square base with sides each measuring roughly 0,9 m). The plate can be anchored to the concrete using the 4 expansion bolts, equipped with 12 MA screws capable of withstanding a tensile load of at least 400 kg. If the anchoring surface is made of a different material, it is necessary to verify its consistency and whether the four anchoring points can withstand a load of at least 1,000 kg. Use the 12 MA screws to fasten the plate.

2. arrange the pipes for routing the electrical cables
3. fasten the four anchor bolts (A) to the foundation plate, inserting a nut and washer (supplied) on each, on the upper and lower sides of the plate

⚠ The lower nut must be screwed up to the end of the thread

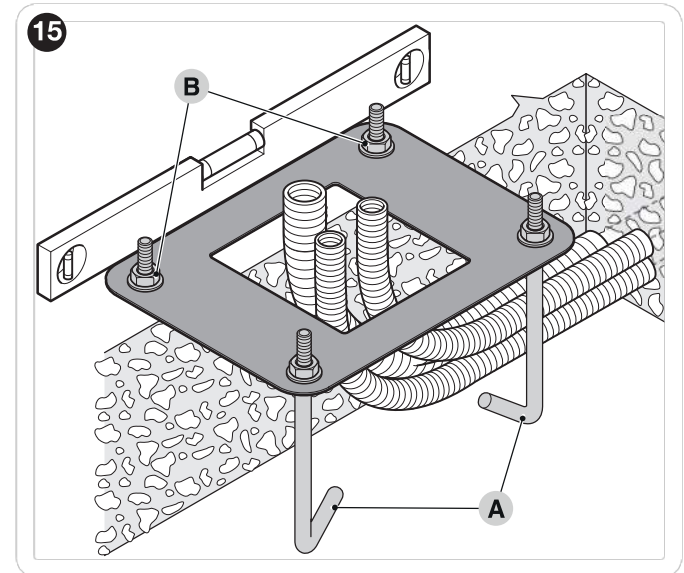

4. pour the concrete and, before it starts to set, place the foundation plate flush with the surface, parallel to the boom and perfectly level
5. wait for the concrete to set completely, which generally takes two weeks
6. remove the four upper nuts and washers from the anchor bolts
7. open the cubicle panel (“Figure 5”)
8. arrange the cubicle properly and secure it with the appropriate nuts and washers removed previously (“Figure 14”).

3.8 - INSTALLING THE BOOM

Proceed as follows to mount the boom of the gate:

1. solo per NUUR6: insert the aluminium connector (D) into one end of the shortest boom and lock it with the screw provided

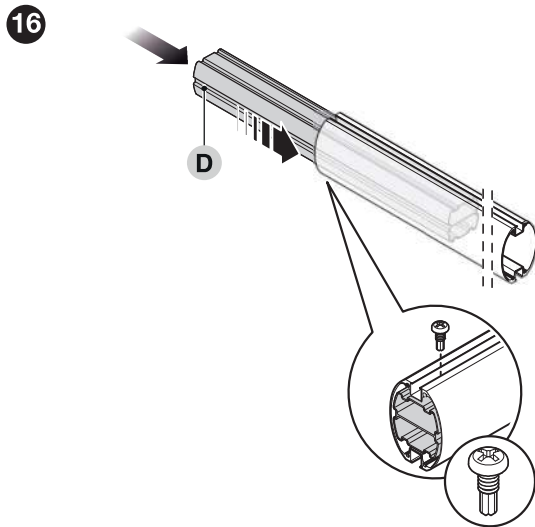

2. **only for booms made up of two pieces:** connect the universal joint (E) into the free ends of the two booms, aligning the holes correctly; loosen the three screws of the joint equally so that the latter can be fastened inside the booms

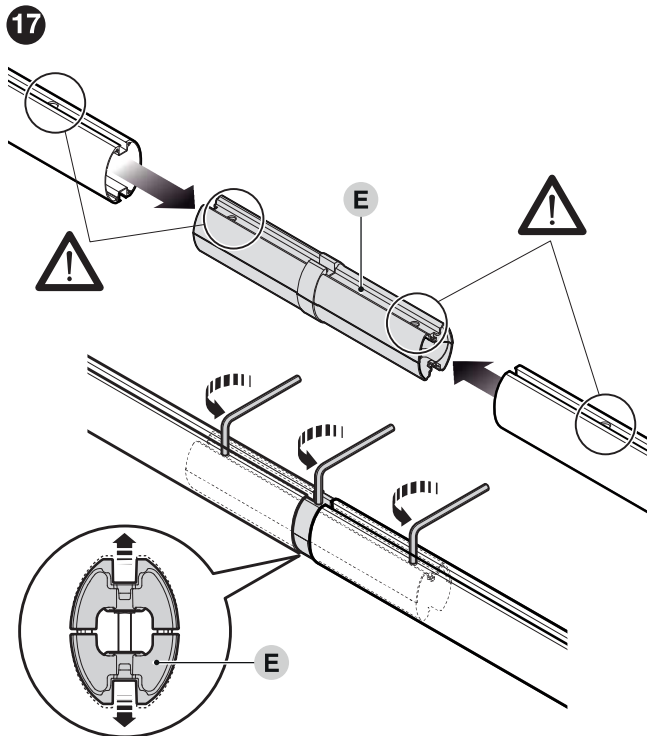

⚠ ATTENTION: if boom lights must be installed, proceed before assembling the bumper rubber.
For installation of the lights, refer to chapter 15.3

3. lightly oil the aluminium rail on both sides
4. along the entire length of the boom, insert the rubber impact protectors through the slots (F) alternating them with the relevant joints (G); the rubber protector can protrude roughly 1 cm from the end of the boom

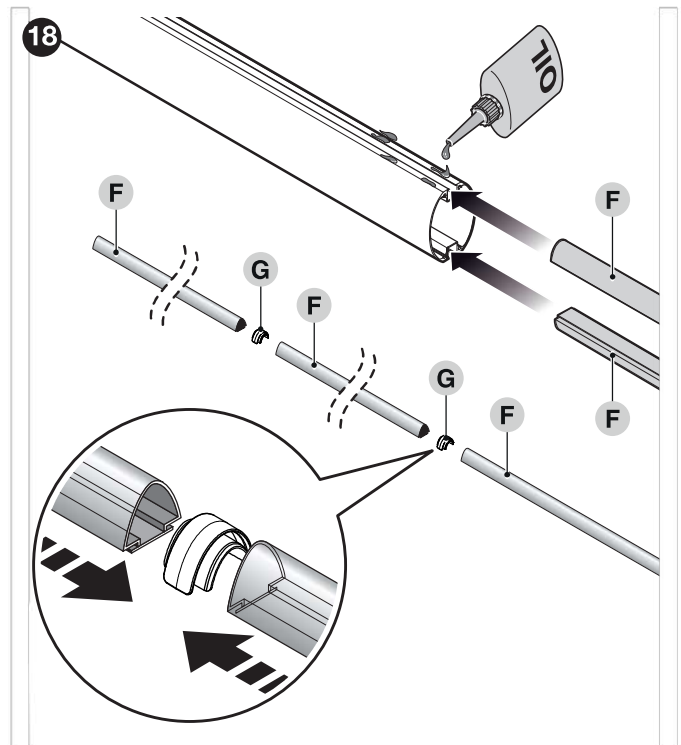

5. put on the boom cap (H) and secure it with the two screws
6. position and fit together the two rubber protector caps (I)

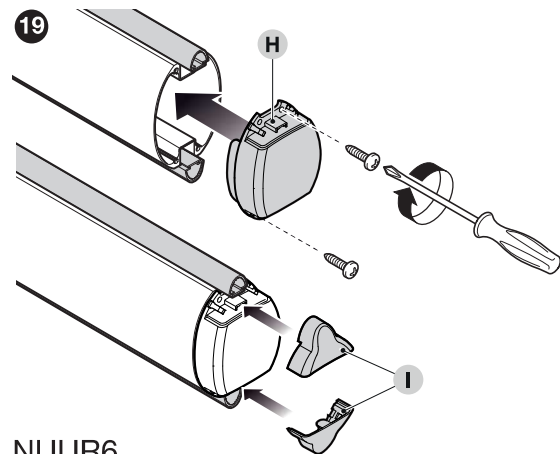

NUUR6

NUUR4

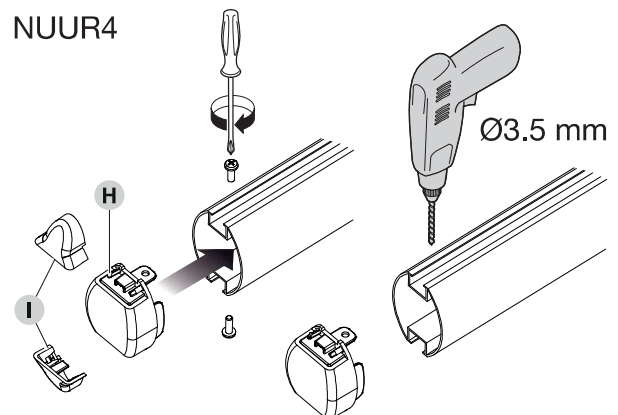

7. **NUUR4**: position the support (**B**) on the boom and fasten it to the plate with the specific screws

NUUR6: position the support (**B**) on the boom and fasten it to the counter-plate (**C**) then fasten everything to the plate with the specific screws

! For booms formed in two parts, the shortest part of the boom must be fastened to the barrier lift.

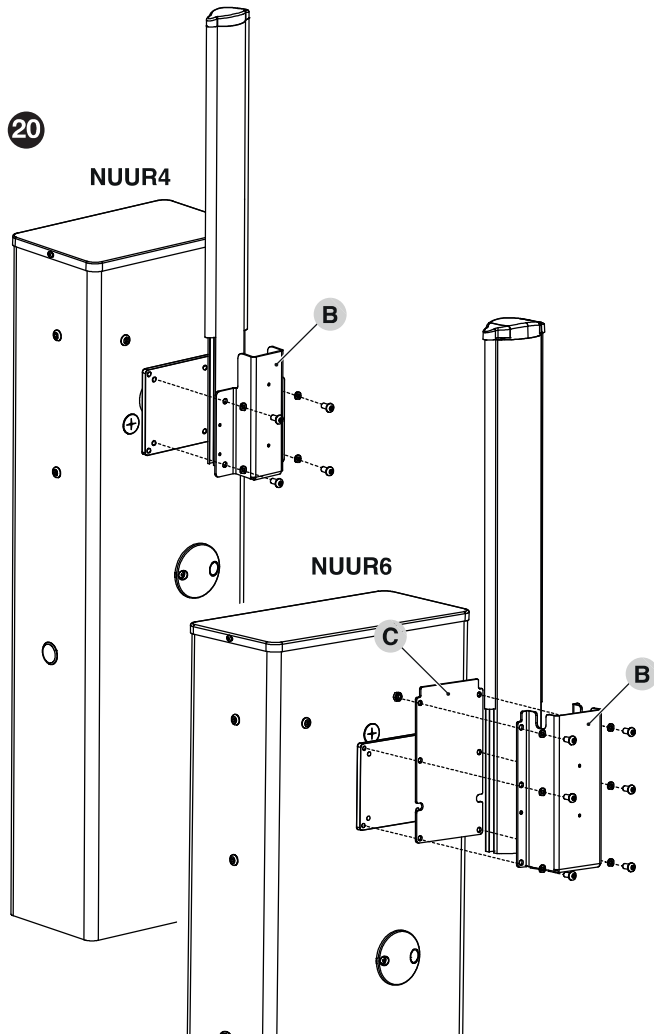

8. position the cover of the support and fasten using the screws supplied

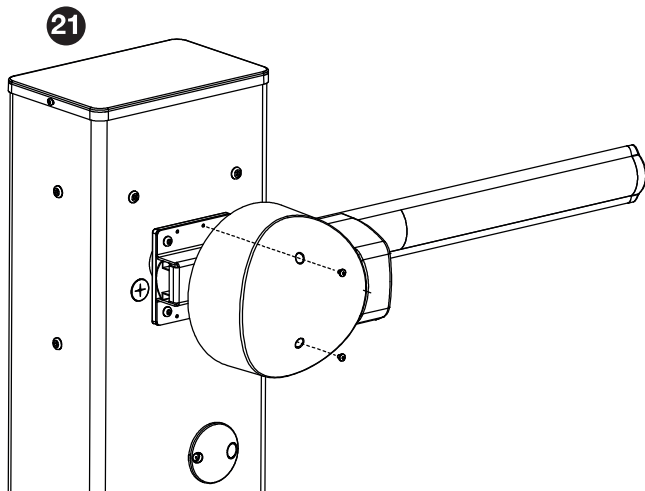

9. in the **NUUR4** version, install plate **D**

22

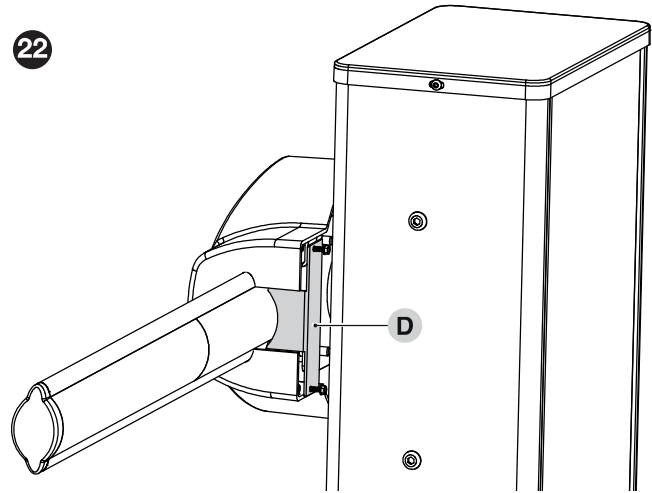

After installing the boom and the rubber impact protector, before proceeding further, the other accessories – if relevant – must be installed on the boom. To install them, refer to the respective instruction manuals.

3.9 - ADJUSTING THE MECHANICAL LIMIT SWITCHES

To adjust the limit switches, proceed as follows:

1. unlock the gearmotor with the relevant key provided (refer to the “Manually unlocking and locking the gearmotor” paragraph)
2. manually move the boom so that it completes a full opening and closing manoeuvre
3. turn the screws of the mechanical stops (A - B) to adjust the boom's horizontal position, when it is closed, and its vertical position, when it is open

23

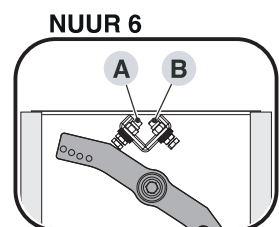
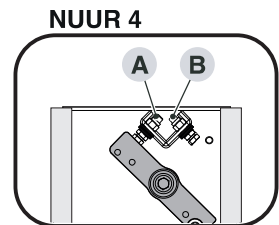
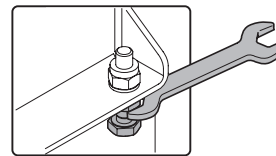
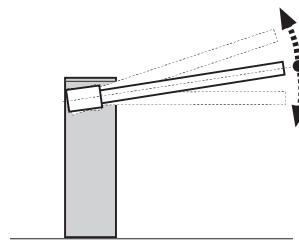

4. after making the adjustments, tighten the nuts vigorously.

3.10 - BOOM BALANCING

The boom balancing operation is used to find the best balance between the overall weight of the boom, inclusive of the installed accessories, and the force opposed by the tension of the balancing spring.

To verify the spring tension, proceed as explained below.

1. unlock the gearmotor with the relevant key provided (refer to the “**Manually unlocking and locking the gearmotor**” paragraph)
2. manually move the boom to about half-way (45°) and leave it stationary
3. if the boom does not stay in position, loosen nut (A) on the spring
4. if the boom tends to rise, reduce the tension of the spring by turning the stretcher (B) anti-clockwise. On the other hand, if the boom tends to fall, increase the spring tension by turning the stretcher (B) clockwise.

24

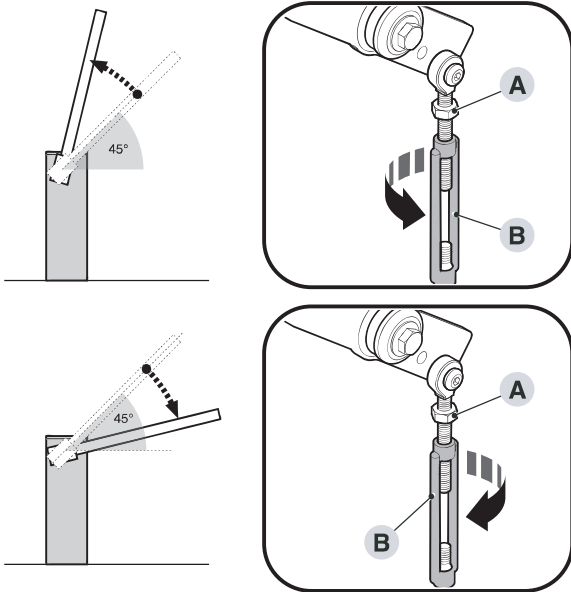

5. repeat the operation by positioning the boom also at roughly 20° and 70°. If the boom remains stationary in its position, it means that it is correctly balanced; a slight imbalance is allowed, but the boom must never move substantially
6. tighten nut (A) for the spring
7. lock the gearmotor.

3.11 - MANUALLY UNLOCKING AND LOCKING THE GEARMOTOR

The gearmotor is equipped with a mechanical unlocking system that allows for opening and closing the boom manually. These manual operations should only be performed in case of a power outage, malfunctions or during the installation phases.

To unlock the device:

1. turn the key slot cover
2. insert the key (A) and turn it towards the left or right

25

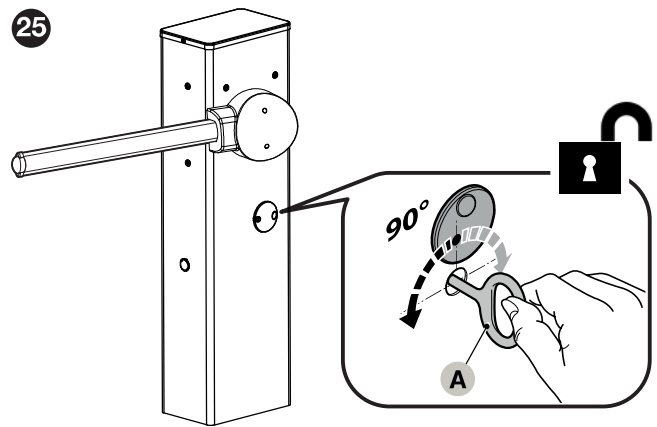

3. at this point, you can manually move the boom to the desired position.

To lock the device:

1. turn the key (A) back to its initial position
2. remove the key
3. turn the key slot cover.

4 - ELECTRICAL CONNECTIONS

4.1 - PRELIMINARY CHECKS

⚠ All electrical connections must be made with the system disconnected from the mains electricity and with the back-up battery (if present) disconnected.

⚠ The connection operations must only be carried out by qualified personnel.

To carry out the electrical connections:

1. open the control unit box
2. pass the electric cables inside the barrier lift, starting from the bottom and working towards the control unit
3. Pass the power cable using the cable gland A and connect it using the terminal L N
4. tighten the cable gland
5. pass the remaining cables using the cable glands B
6. install the connections, with reference to the wiring diagram in Figure 28. For further convenience, the terminals can be removed.

26

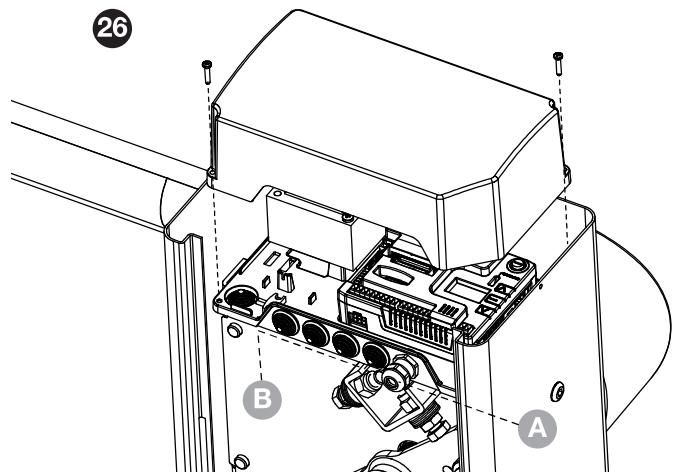

⚠ Before closing the cover, program the system (refer to paragraph “PROGRAMMING”).

5 - CONTROL UNIT

KB24 is provided with a display that, not only makes programming simple, but also allows a continuous monitoring of the input statuses; in addition, thanks to a menu structure, the working schedule and the operation logic can be set easily.

In compliance with the European standards concerning electrical safety and electromagnetic compatibility (EN 60335-1, EN 50081-1 and EN 50082-1) it has been equipped with the low voltage circuit total electric insulation (motors included) from the network voltage.

Other characteristics:

- Power supply protected from short circuits within the controller, on the motors and on the connected accessories.
- Adjustment of the power by partializing the current.
- Detecting obstacles by monitoring the current on the motors.
- Fine adjustment of the stroke.
- Tests for safety devices (photocells, safety ribbons and mosfet) before each opening.
- Deactivation of safety inputs through the configuration menu: no jumper is required for terminals concerning safety devices that have not been installed, yet. You will only need to disable this function from its relevant menu.
- The device can operate without mains power, by using the optional battery pack (code 161261).
- Possibility of connecting an electromagnet (suction cup) to keep the rest bar closed.
- Possibility of using the light outputs, flashing indicator and electro magnets to control a traffic light in one direction or two directions (alternating one-way).
- Low voltage output that can be used for a signal light or a 24V flashing light.
- Auxiliary relay with programmable logic for courtesy light, flashing light or other use.
- ENERGY SAVING FUNCTION
- Operation with the optional SYNCLUX module that allows:
 - Synchronised operation of the two barriers.
 - Control of a RGB led strip along the boom (one side only or both sides) to indicate the status of the barrier.
 - Traffic light control in one direction or two directions without giving up standard outputs.
 - Two programmable functions using clean contact relay.

5.1 - POWER SUPPLY

⚠ WARNING: Installation of control unit and safety devices must be carried out with power disconnected.

The control unit must be fed by a 230V-50Hz or 120V-60Hz electric line, protected by a differential magnetothermal switch complying with the law provisions in force.

Connect the power supply wires to terminals **L** and **N** on the board located next to the transformer.

Connect the earth cable to terminal \perp

27

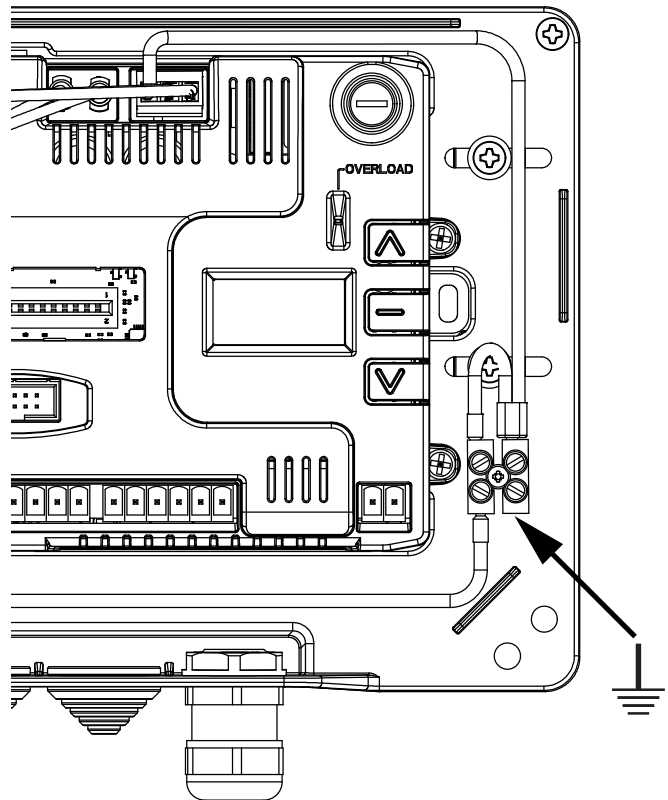

5.2 - ECO-LOGIC POWER SUPPLY

The barrier can be powered by the solar power system ECO-LOGIC.

Install the ECO-LOGIC system following the instructions included with the product.

Connect the output of the battery box (black connection) to the BATTERY connector of the control unit.

NOTE: it is recommended the batteries be pre-charged prior to installation

⚠ WARNING: activate the Energy Saving function

⚠ WARNING: If you use the ECO-LOGIC to power the barrier, do not connect the power supply on terminals N and L

5.3 - INGRESSI DI ATTIVAZIONE

The control unit KB24 has two activation inputs available, whose functions depend on the programmed mode of operation (See voice **SET** on the programming menu):

Standard mode: first input (START1) controls the opening, the closing and the arrest depending on the programming mode set. The second input (START2) causes the opening of the barrier MASTER when it is activated the synchronized operation of two barriers.

Open/Close and Dead Man mode: an input command on push-button START1 always commands the opening and an input command on push-button START2 always commands the closing.

- In the Open/Close mode the command is of impulsive type, that is, an impulse causes the total opening or closing of the barrier.
- In the Dead Man mode, the command is of the monostable type, that is the barrier opens or closes as long as the contact is closed and arrests immediately if the contact becomes open.

Input/Output Mode: this function must be set when a traffic light is connected for an alternating one-way. The command is impulsive, that is, a pulse causes the bar to open completely; if the command arrives on the input START1 the green switches on in the entry direction, if it arrives on the input START2 the green switches on in the exit direction.

Clock mode: it is analogous to the standard mode, but the barrier remains opened as long as the contact remains closed on the input START1; when the contact comes opened begins the pause countdown, which upon expiring the barrier recloses. This function allows programming throughout the day the opening hour cycles of the barrier, using for this an external timer. It is indispensable to enable automatic reclosing.

 **ATTENTION: in all modes, the input commands must be connected to devices with normally opened contacts.**

Connect the cables of the device that commands the START1 input between terminals **J1** and **J4** of the control unit.

Connect the cables of the device that commands the START2 input between terminals **J2** and **J4** of the control unit.

The function associated to the START1 input command can also be activated by pressing push-button **↑** from outside the programming menu, or by means of a remote control command memorized on channel 1 (see the instructions of receiver MR).

The function associated to the START2 input command can also be activated by pressing push-button **↓** from outside the programming menu, or by means of a remote control command memorized on channel 2 (see the instructions of receiver MR).

5.4 - STOP

For greater safety it is possible to install a push-button that when pressed causes immediate stop of the barrier. The switch must have a normally closed contact that opens in case of set in action.

If the stop switch is set in action while the barrier is opened, the automatic reclosing function becomes disabled; in order to reclose the barrier it is necessary to give a start command (if the start function in pause is disabled, it becomes temporarily reenabled in order to allow the lock release of the barrier).

Connect the stop switch cables between cables **J3** and **J4** of the control unit.

5.5 - PHOTOCELLS

Photocells can be activated in two ways:

1. Only during closing: in which case the passage in front of the beam would cause the immediate reopening.
2. During the opening and closing: in which case the interruption of the beam causes the immediate arrest. When the beam is freed, a complete reopening of the barrier occurs.

 **ATTENTION: install the photocells to cover the entire opening / closing surface of the boom.**

The control unit KB24 provides 24VDC power supply for the photocells and it can test their performance before beginning the opening of the boom. An electronic fuse that shuts down the power supply in case of an overload protects the power supply terminals of the photocells.

- Connect the feeder cables of the photocells transmitter between terminals **Z3 (+)** and **Z2 (-)** of the control unit.
- Connect the feeder cables of the photocells receiver between terminals **Z1 (+)** and **Z2 (-)** of the control unit.
- Connect the Common and the N.C. (Normally Closed) contact of the photocells receiver on terminals **J6 (PHOTO)** and **J9 (COM)** of the control unit. Use the exits with normally closed contact.

 **ATTENTION:**

- if more photocells copies of the same kind are to be installed, their outputs must be connected in series.
- if reflection photocells are to be installed, the power supply must be connected to terminals **Z3 (+)** and **Z2 (-)** of the control unit to carry out the functional test.
- The photocells are not powered when the control unit switches to ENERGY SAVING mode

5.6 - SAFETY RIBBONS

They can be installed located on the anti-shock rubber bumper strip, which normally comes provided with the boom kit.

In case of intervention during the closing, reopening and disabling of the automatic closing occurs.

The control unit is able to carry out either the classic safety ribbons with normally closed contact, or conductive rubber safety ribbons with 8,2 kohm nominal resistance.

Connect the cables between terminals **J8** and **J9** of the control unit.

 **ATTENTION:** In order to meet the requirements of the EN12978 rules, it is necessary to install safety ribbons controlled by a control unit continuously checking the proper working. If using control units suited to the test by power outage, connect the power supply cables of the control unit between terminals **Z3 (+)** and **Z2 (-)** of the control unit.

Otherwise, connect them between terminals **Z1 (+)** and **Z2 (-)**.

 **ATTENTION:**

- If more safety ribbons with normally closed contact are used, their outputs must be connected in series.
- If more safety ribbons with pressure conductive rubber are used, their outputs must be connected in cascade style and only the last one must be ended on the nominal resistance.
- The active edges, connected to the accessory power supply, are not active when the control unit switches to ENERGY SAVING mode

5.7 - COURTESY LIGHT

The COURTESY LIGHT output consists of a simple N.O. contact (Normally Open Circuit) and does not provide any power supply. Thanks to the COURTESY LIGHT output, the control unit KB24 allows the connection of a utility light (a courtesy light or a garden light, for example), which is programmed automatically, or by arming channel 4 of the MR receiver.

The COURTESY LIGHT output consists of a simple N.O. contact and does not provide any power supply. The maximum output of the contact is of 230V - 5A

Connect the cables to terminals **B1** and **B2**.

5.8 - LOW VOLTAGE LIGHT OUTPUT

The control unit has a 24 VDC output that allows connection of a maximum load of 12 W.

This output can be used to connect a warning light, indicating the status of the barrier, or for a low voltage flashing light.

Connect the low voltage signal light or flashing light wires to terminals **Z5 (+)** and **Z4 (-)**.

 **CAUTION:** Pay attention to the polarity of the connected device if necessary.

5.9 - ANTENNA

We suggest to use the external aerial (model: ANS433) in order to guarantee the maximal range.

Connect the antenna hot pole to terminal **A2** of the control unit and the braiding to terminal **A1**.

5.10 - HOLDING MAGNET

The control unit KB24 is equipped with an output for feeding an holding magnet. Through a dedicated menu it is possible to regulate the output voltage up to a maximum value of 24Vdc. The power supply to the holding magnet is interrupted at the beginning of every opening (with adjustable anticipation from the menu) and restored at the end of the closing (with adjustable delay from the menu).

Connect the power supply to the holding magnet between terminals **Z5 (+)** and **Z6 (-)**.

PLEASE NOTE: The locking electromagnet is connected to the accessory power supply. Hence, it is essential to deactivate the energy saving function to use it.

5.11 - MAGNETIC COIL OR PRESENCE SENSOR

NOTE: if the ENERGY SAVING function is enabled, this function is not available

The ST.NC input can be used for the connection of a presence detection device for vehicles (magnetic coil) or people (presence sensor) in the barrier area, using opening of a normally closed contact.

When presence is detected, the bar is raised and it is not possible to lower it until the area is freed.

When the sensor indicates the area is free again, the count starts for automatic closure time, if enabled.

The same input can be used for the fire-prevention sensor. In this case, the bar is not lowered automatically when contact is reset.

Connect the cables to terminals **J5** and **J9**.

6 - ELECTRICAL CONNECTIONS

28

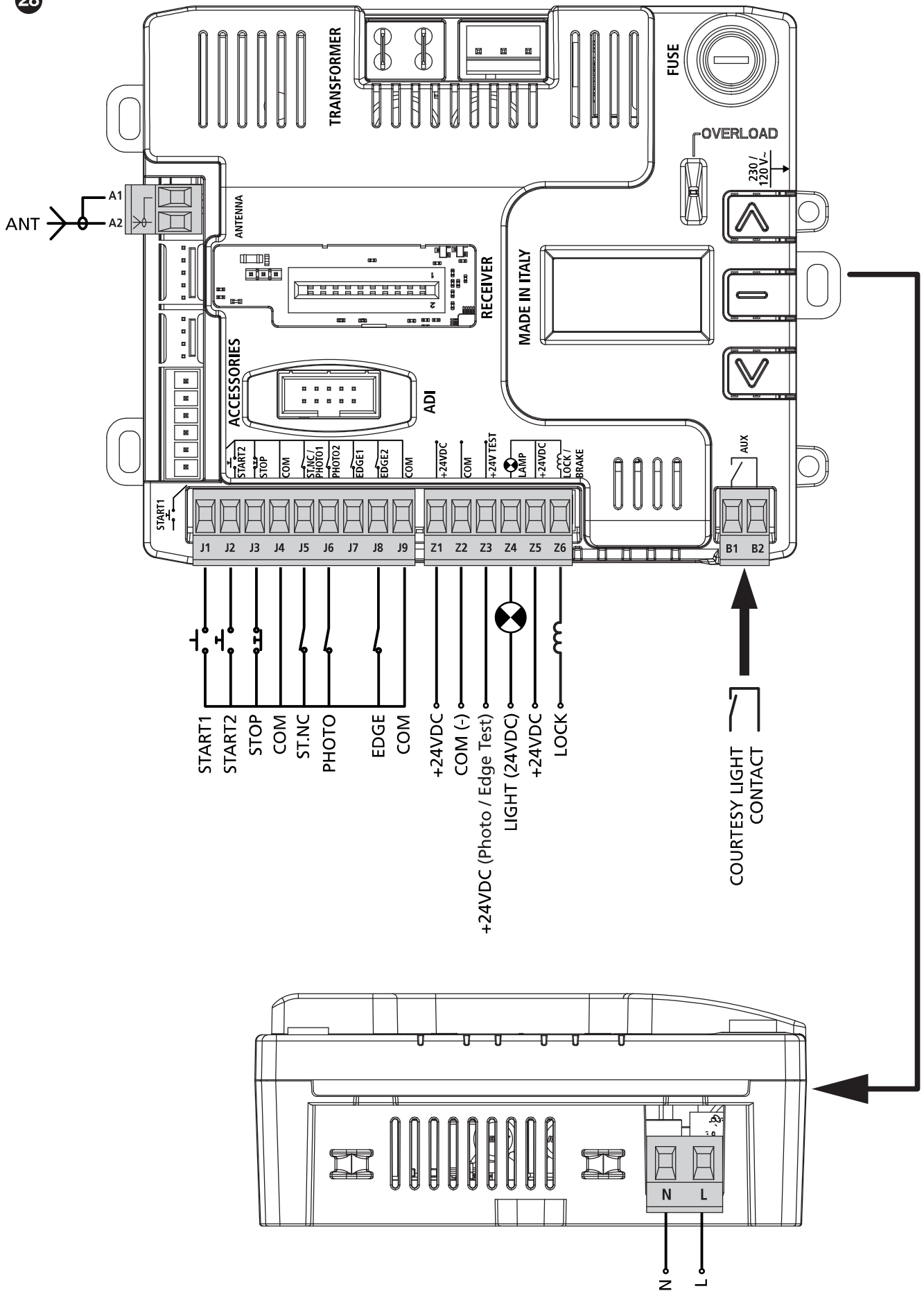

L	Power supply feeding phase 230V / 120V
N	Neutral feed 230V / 120V
A1	Antenna shield
A2	Antenna
J1	START1 – Activation input 1 for connection of traditional devices with N.O. (normally open) contact
J2	START2 - Activation input 2 for connection of traditional devices with N.O. (normally open) contact
J3	STOP Command. N.C. (normally closed) contact
J4	Common (-)
J5	ST.NC - START input normally closed, to use for a presence sensor
J6	Photocell. N.C. (normally closed) contact
J7	Setup for future use
J8	Safety ribbon
J9	Common (-)
Z1	Power output 24Vdc for photocells and other accessories
Z2	Accessory power common (-)
Z3	Power supply - photocell/optical edge TX for functional Test. Connect power supply cables of photocells transmitter between terminals Z2 and Z3
Z4	Low voltage light output (-) (Warning light or flashing light (24V))
Z5	Power supply for low voltage lights and hold electromagnets (+)
Z6	Hold electromagnet (-)
B1-B2	Contact N.A. (max. 230V-5A) for additional courtesy light or flashing light

ADI	ADI interface
RECEIVER	Plug in receiver
FUSE	5 A
MAINS	It signals that the control unit is being powered
OVERLOAD	It signals an overload on the accessories power supply

7 - PANNELLO DI CONTROLLO

7.1 - DISPLAY

When the power supply is enabled, the display will show:

- all the segments for 1 second
- model of the control unit for 1 second
- firmware version for 2 seconds

Panel will be viewed upon completion of this test:

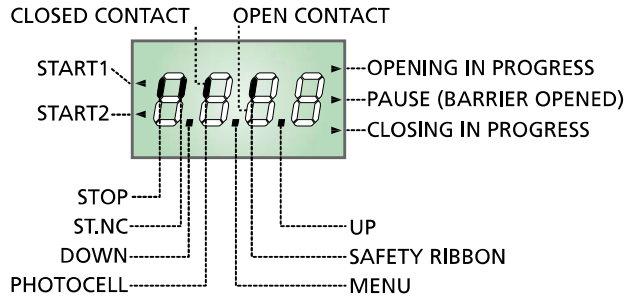

PLEASE NOTE: The display is off when the control unit is in ENERGY SAVING mode.

The control panel represents the physical status of the terminal board contacts and of the program mode keys: if the upper vertical segment is on, the contact is closed; if the lower vertical segment is on, the contact is open (the above picture shows an instance where the inputs PHOTOCCELL, SAFETY RIBBONS and STOP have all been correctly connected).

Points being among display digits show the status of programming push-buttons: as soon as a push-button is pressed, its relevant point turns on.

The arrows on the left of the display show the state of the start inputs.

The arrows light when the related input is closed.

Le frecce a destra del display indicano lo stato della barriera:

- The arrow further at the top is illuminated when the barrier is in opening phase. If it flashes, it indicates that the opening has been caused from the participation of an emergency device (obstruction sensor or obstacle detector).
- The center arrow indicates that the barrier is opened in pause. If it flashes it means that the time counter is active and counting for the automatic closing.
- The lower arrow is illuminated when the barrier is in phase of closing. If it flashes it indicates that the closing has been caused by an interruption of an emergency device (obstruction sensor or obstacle detector).

7.2 - USE OF THE KEYS FOR PROGRAMMING

The control unit functions and times are programmed by means of a special configuration menu, which can be accessed and explored by using the 3 keys, **↑**, **↓** and **OK**, located on the side of the control unit display.

PLEASE NOTE: Outside the configuration menu, pressing the **↑ key activates the START command, pressing the **↓** key activates the PEDESTRIAN START command.**

There are the following three kinds of menu items:

- Function menu
- Time menu
- Value menu

Function menu setup

Function menus allow selecting a function from among a group of available options. When you enter into a function menu, the current active option will be viewed; you can scroll all available options through **↓** and **↑** keys. By pressing the **OK** key, you will activate the option viewed and you will return to the configuration menu.

Time menu setup

Time menus allow setting a function duration. When you enter into a time menu, the current setup value will be viewed; the display mode depends on the current value:

- Each time you press **↑** key, current time value increases and each time you press the **↓** key, current time value decreases.
- By holding down the **↑** key, you can quickly increase the time value, up to reach the max. value allowed for this item.
- Vice versa, by holding down the **↓** key, you can quickly decrease the time value down to reach **0.0"**
- In some circumstances, setting the value to **0** means that the relevant function is disabled, in this case, **no** will appear instead of **0**
- By pressing on **OK** you will confirm the displayed value and you will return to the configuration menu.

Value menu setup

Value menus are similar to time menus; however, the setup value can be any number.

By holding down **↑** or **↓** keys, the value will increase or decrease slowly.

By pressing on **OK** you will confirm the displayed value and you will return to the configuration menu.

The main programming menus of the control unit are shown in the next pages.

To go through the menus use the three keys **↑**, **↓** and **OK** according to the following chart:

	Press and release the push-button OK
	Keep pressed the push-button OK for 2 seconds
	Release the push-button OK
	Press and release the push-button ↑
	Press and release the push-button ↓

8 - ACCESSING THE CONTROL UNIT SETTINGS

1. Press and hold the **OK** key until the display shows the menu desired
2. Release the **OK** key: the display will show the first item in the sub-menu
 - **PrG** Programming the control unit (chapter 13)
 - **Cnt** Cycle counter (chapter 12)
 - **tM** Clock and timer programming (chapter 16)
 - **ESC** Programming of the SYNCLUX accessory device
 - **RPP** Self-learning of the stroke (chapter 11)
 - **dEF** Loading the default parameters (chapter 9)

⚠ WARNING: in case no operation is carried out for more than one minute, the control unit exits from the programming mode without saving any of your setups and changes, which will get lost.

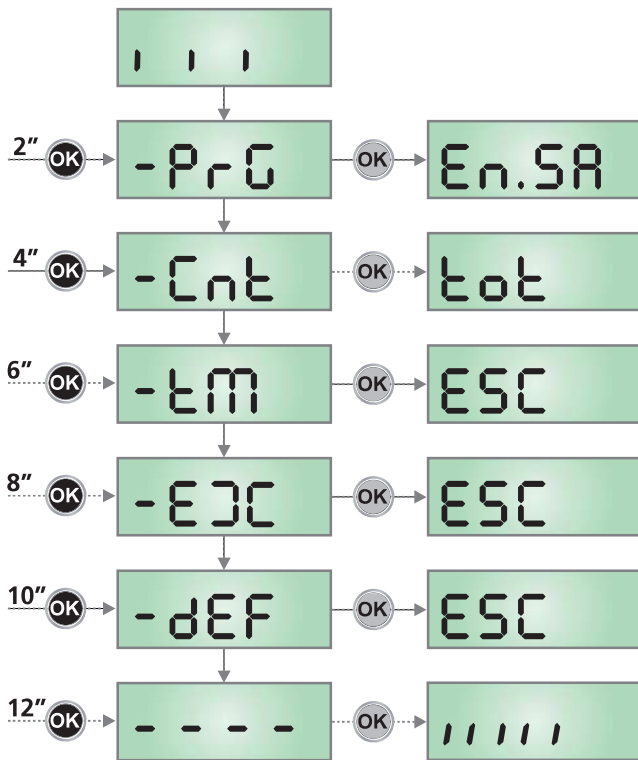

9 - LOADING THE DEFAULT PARAMETERS

If necessary, it is possible to restore all parameters to their standard or default values (see the final summary table).

⚠ PLEASE NOTE: This procedure results in the loss of all customised parameters.

1. Press and hold the **OK** key until the display shows **-dEF**
2. Release the **OK** key: the display shows **ESC** (only press the **OK** key if it is desired to exit this menu)
3. Press the **↓** key: the display shows **dEF.**
4. Press the **OK** key: the display shows **no**
5. Press the **↓** key: the display shows **S₁**
6. Press the **OK** key: all parameters are overwritten with their default values (see Chapter 13), the control unit exits programming mode and the display shows the control panel.

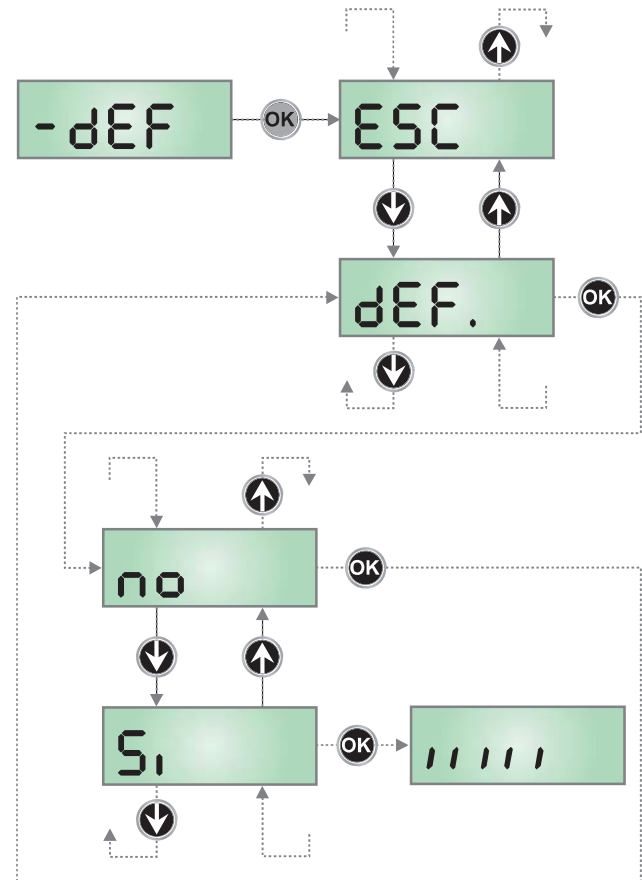

10 - QUICK CONFIGURATION

This paragraph concerns a quick procedure to set the control unit and set it at work immediately.

We recommend following these instructions, in order to check quickly the correct operation of control unit, motor and accessories, and then changing the configuration in case of any non-satisfactory parameter.

1. Call up the default configuration: see chapter 9
2. Set items
`dir - Stop - Foto - Cos`
For the position of the item menus inside the main menu and for the options related to each item menu, refer to the chapter 13.
3. Check that the automation work properly and if necessary modify the configuration of the desired parameters.

11 - EMERGENCY DEAD MAN OPERATION

This operational mode can be used to move the gate in DEAD MAN mode in particular cases, such as installation/maintenance or in the case of malfunctioning of photocell, edge, limit switches or encoder.

To activate the function the START command must be pressed 3 times (presses must last at least 1 second; the pause between commands must last at least 1 second).

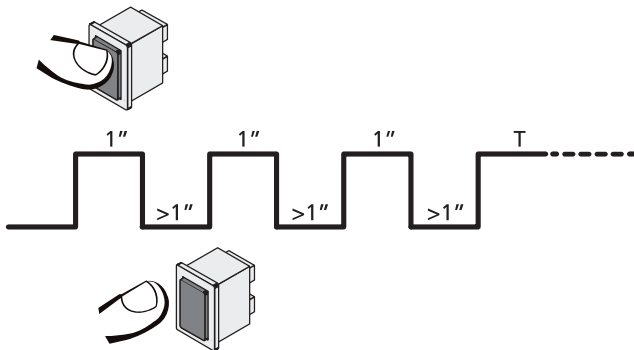

The fourth START command activates the gate in MAN PRESENT mode. To move the gate keep the START command pressed for the duration of the operation (time T). The function will automatically turn off after 10 seconds of inactivity of the gate.

NOTE: if the `Start` parameter is set as `Startn`, the Start command (from the terminal block or remote control) moves the gate in the open and closed directions alternatively (unlike the normal DEAD MAN mode).

12 - READING THE COUNTER OF THE CYCLES AND EVENTS MEMORY

KB24 control unit counts the completed opening cycles of the barrier and, if requested, it shows that service is required after a fixed number of cycles.

Furthermore, events can be recorded which occurred during operation, associating to each a code and a date/time in which each occurred; this information must be communicated to the support service if problems arise.

ATTENTION: to have the correct date/time information, you must set the clock built into the control unit, see chapter 19.

There are 3 counters available:

- A totalizing counter for completed opening cycles that cannot be zeroed (option `tot` of item `Cnt`)
- A downward counter for the number of cycles before the next request for service (option `serv` of item `Cnt`).

When the counter of missing cycles for the next maintenance intervention reaches zero, the control unit signals the maintenance request by means of an additional pre-flashing of 5 seconds. The signal is repeated at the beginning of each opening cycle, until the installer accesses the meter reading and setting menu, possibly programming the number of cycles after which maintenance will be required again. If a new value is not set (i.e. the counter is left at zero), the maintenance request signaling function is disabled and the signaling is no longer repeated.

- Events counter (option `even`)

The scheme hereafter shows how to read the totalizing counter, how to read the number of cycles before the next service is required as well as how to program the number of cycles before the next request for service (as for the example shown, the control unit completed no. 12451 cycles and there are no. 1300 cycles before the next service request; the code of the last recorded event is 176, and it occurred at 14.14.19 on 20 August).

Area 1 is the reading of the total number of completed cycles; through \uparrow and \downarrow keys, you can alternate the display of thousands or units.

Area 2 is the reading of the number of cycles before the next request for service: its value is rounded down to the hundreds.

Area 3 represents the setting of this counter: on first pressing of the key \uparrow or \downarrow the current value of the counter, it is rounded off to the thousand, every subsequent press increases the setting by 1000 units or decreases by 100. The previously displayed count is lost.

Area 4 represents reading of the events memory.

The first data is an index that allows identification of the event: `n 1` is the last event recorded, `n 2` is the previous one and so on. The other data are automatically displayed in succession and provide information on the date/time (each data remains displayed for approximately one second, if you want to temporarily stop the display, keep the MENU key pressed); the last data displayed is the code of the event (in some cases, after the event code additional data is displayed), then the sequence restarts from the index.

The data are displayed for 1 minute, after which the display returns to normal view.

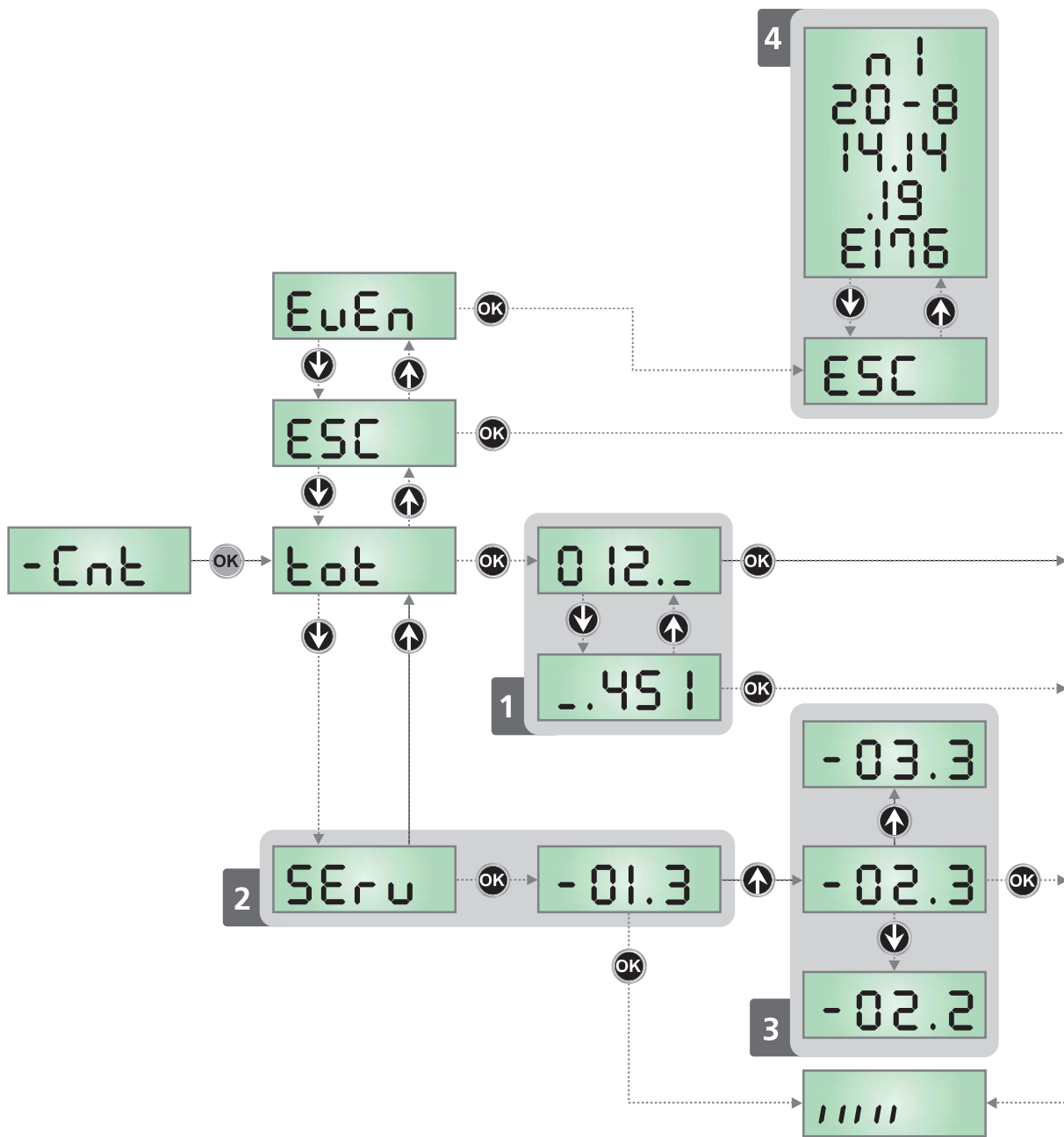

13 - PROGRAMMING THE CONTROL UNIT

The configuration menu **-PrG** consists in a list of configurable items; the display shows the selected item.

By pressing **↓**, you will pass to the next item; by pressing **↑**, you will return to the previous item.

By pressing **OK**, you can view the current value of selected item and possibly change it.



The last menu item (**FinE**) allows storing the carried out changes and going back to the control unit normal operation. You must exit from programming mode through this menu item if you do not want to lose your configuration.

⚠ WARNING: in case no operation is carried out for more than one minute, the control unit exits from the programming mode without saving any of your setups and changes, which will get lost.

By holding down the **↓** or **↑** keys, configuration menu items will scroll fast, until item **FinE** or **En.SA** is viewed.

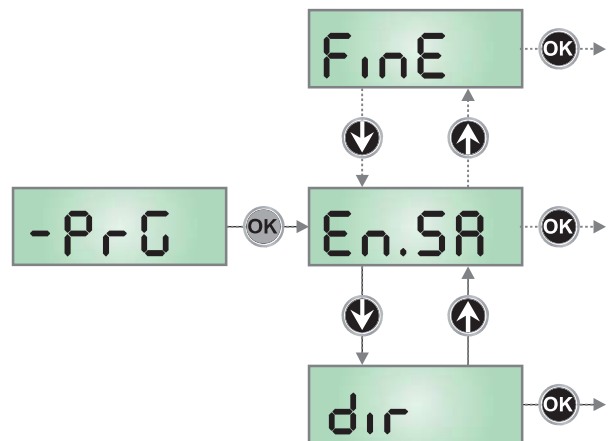
In this way, you can quickly reach either the top or bottom of the list.



PARAMETER	VALUE	DESCRIPTION	DEFAULT NUUR4	DEFAULT NUUR6	MEMO
EnSR		<p>Energy saving function</p> <p>This function is useful for reducing the energy consumption of the automation device while in stand-by mode. If the function is enabled, the control unit will enter ENERGY SAVING mode under the following conditions:</p> <ul style="list-style-type: none"> • 30 seconds after completion of an operational cycle • 30 seconds after an opening (if automatic closure is not enabled) • 30 seconds after exiting the programming menu <p>In ENERGY SAVING mode, power to the accessories, display, flashing lights and closure electromagnets is deactivated. ENERGY SAVING mode is exited:</p> <ul style="list-style-type: none"> • If an operational cycle is activated • If one of the menus is accessed 	no	no	
	no	Function deactivated			
	Si	Function activated			
	RUto	The energy saving mode is automatically enabled only if the power supply mains is down, i.e. In the event of a blackout with battery backup			
dir		<p>Direction</p> <p>Set up the functioning directions. This parameter must be set up based on the RIGHT or LEFT installation of the barrier (chapter 3.6)</p>	DX	DX	
	DX	Installation on the right (DX)			
	SX	Installation on the left (SX)			
L.AdJ		Fine adjustment of the stroke	100	100	
	50 - 150	<p>This menu allows you to change the duration of the opening and closing maneuver if it is not correct with respect to the adjustment of the limit switches. If the rod hits the limit switches and SEnS appears on the display, set a lower value. If the auction does not close completely, set a higher value.</p>			
t.ASE		Holding magnet anticipation time	0.0"	0.0"	
	0.0" - 5.0"	<p>This menu allows regulating the anticipated time with which the holding magnet is unblocked before the barrier comes set in opening action.</p> <p> ATTENTION: if the holding magnet is not present, set this parameter to zero.</p> <p>NOTE: The locking electromagnet is connected to the accessory power supply. Hence, it is essential to deactivate the energy saving function to use it.</p>			
t.rSE		Holding magnet delay time	0.0"	0.0"	
	0.0" - 5.0"	<p>This menu allows regulating the delay with which the holding magnet jams after the barrier has finished closing.</p> <p> ATTENTION: if the holding magnet is not present to set up this parameter to zero.</p> <p>NOTE: The locking electromagnet is connected to the accessory power supply. Hence, it is essential to deactivate the energy saving function to use it</p>			

PARAMETER	VALUE	DESCRIPTION	DEFAULT NUUR4	DEFAULT NUUR6	MEMO
P.SEr		Holding magnet power	no	no	
	no - 100	This menu allows regulating the power with which the electromagnetic vacuum gripper becomes blocked. ⚠ ATTENTION: if the holding magnet is not present, set up this parameter to zero. NOTE: The locking electromagnet is connected to the accessory power supply. Hence, it is essential to deactivate the energy saving function to use it.			
t.PrE		Pre-blinking time	1.0"	1.0"	
	0.5" - 1'00	Before any barrier movement, blinker will be activated for t.PrE time, to warn about the incoming motion			
	no	Function deactivated			
t.PrCh		Different closing pre-flashing time	no	no	
	0.5" - 1'00	If this parameter has a value assigned to it, the control unit will activate pre-flashing prior to closure for the length of time set in this menu (adjustable time from 0.5" to 1'00)			
	no	The closing pre-flashing time corresponds to t.PrE			
P.AP		Motor power in opening phase	100	100	
	30 - 100	Percentage compared to the maximum motor power			
P.Ch		Motor power in closing phase	70	70	
	30 - 100	Percentage compared to the maximum motor power			
P.o.AL		Motor power during the realignment phase The realignment phases intervene in the first closure after resetting and during learning of the limit switches.	30	60	
	10 - 70	Percentage compared to the maximum motor power			
r.AM		Starting ramp	2	4	
	0 - 6	In order not to stress too much the motor, when the motion starts the power is gradually increased, until reached the set value or 100% if the take-off is enabled. Higher is the set value, longer the length of time of the ramp, that is the time necessary to reach the value of nominal power.			
SEn.A		Opening obstacles sensor	4.0 A	7.0 A	
	0.0A - 8.0A	This menu allows adjustment of sensor sensitivity to obstacles. When the current absorbed by the motor exceeds the value set, the control unit detects an alarm. Detection of an obstacle causes the bar to stop. Automatic closure is disabled the second time the cycle is interrupted by an obstacle. If the obstacle is detected near the limit switch, it is interpreted as a mechanical stop.			
	no	Function deactivated			
SEn.C		Closure obstacles sensor	4.0 A	7.0 A	
	0.0A - 8.0A	This menu allows adjustment of sensor sensitivity to obstacles. When the current absorbed by the motor exceeds the value set, the control unit detects an alarm. Detection of an obstacle causes complete re-opening, to free the obstacle. Automatic closure is disabled the second time the cycle is interrupted by an obstacle. If the obstacle is detected near the limit switch, it is interpreted as a mechanical stop.			
	no	Function deactivated			

PARAMETER	VALUE	DESCRIPTION	DEFAULT NUUR4	DEFAULT NUUR6	MEMO
rR.AP		Slow down in opening	40	40	
	no - 100	This menu allows regulating the percentage of the ride/drive that is carried out at reduced speed during the last opening stretch			
rR.Ch		Slow down in closing	25	25	
	no - 100	This menu allows regulating the percentage of the ride/drive that is carried out at reduced speed during the last closing stretch			
MFC		Edge of the limit switch This menu allows you to establish that an obstacle, even if detected before pause positioning (barrier open) is however interpreted as a mechanical stop.	10	10	
	1 - 25	Percentage of the stroke relating to the edge			
	no	Function disabled			
St.AP		Start command during the opening phase This menu allows fixing the control unit conduct in case it receives a Start command during the opening phase	PAUS	PAUS	
	PAUS	The barrier closes and enters in pause			
	ChU	The barrier immediately starts to reclose			
	no	The barrier continues to open (the command is ignored)			
St.Ch		Start command during the closing phase This menu allows fixing the control unit conduct in case it receives a Start command during the closing phase	StoP	StoP	
	StoP	The barrier closes and the cycle is considered concluded			
	APER	The barrier reopens			
St.PR		Start command during the pause This menu allows establishing the behavior of the control units if a Start command is received while the barrier is opened in pause	ChU	ChU	
	ChU	The barrier starts to reclose			
	no	The command is ignored			
	PAUS	The pause time becomes recharged (Ch.AU)			
Ch.AU		Automatic Closing In automatic operation, the control unit automatically recloses the barrier at the end of the preset time	no	no	
	no	Function deactivated			
	0.5" - 20'0	The barrier recloses after the time set			
Ch.Tr		Closing after transit During the automatic operation, the pause count down starts from the set up value each time a photocell operates during the pause. If the photocell operates during the opening time, this time will be immediately stored as pause time. This function allows having a fast closing after the transit through the barrier, for which usually a lesser time for Ch.AU (automatic closing) is used	no	no	
	no	Function deactivated			
	0.5" - 20'0	The barrier recloses after the time set			

PARAMETER	VALUE	DESCRIPTION	DEFAULT NUUR4	DEFAULT NUUR6	MEMO
PR.t		Pause after the transit	no	no	
	S _i	In order to render minimum the time in which the barrier remains open, it is possible to make the barrier close as soon as the passage in front of photocells has ended. If the automatic operation is enabled, the Ch.t value is loaded/programmed as time of pause			
	no	Function deactivated			
bl.oU		Forced opening due to blackout	no	no	
	no	Function disabled			
	AP	In case of blackout the barrier opens			
	AP.Ch	In case of blackout the barrier opens and closes again when the mains power returns			
LUC_i		Courtesy lights This menu allows setting up the operation of the courtesy lights automatically during the barrier's opening cycle	t.LUC	t.LUC	
	t.LUC	Timed functioning (from 0 to 20')	1'00	1'00	
	no	Function disabled			
	CiCL 0 - 20'	Turned on for the entire duration of the cycle. At the end of the cycle, the lights can be kept on for a time settable from 0 to 20 minutes			
AUS		Auxiliary channel This menu allows setting the operating of the relay of the lighting of the courtesy lights by means of a remote control stored on the channel 4 of the receiver MR	Mon	Mon	
	t.m	Timed functioning (from 0 a 20')			
	b.st	Bistable functioning			
	Mon	Monostable functioning			
SP.R		Setting low voltage light output	FLSh	FLSh	
	FLSh	Flashing function (fixed frequency)			
	no	Function disabled			
	SEM	Traffic light function (for the settings, see the SEM parameter that follows)			
	W.L.	Spy lamp function: it indicates in real time the state of the barrier, the type of flash indicates the four possible conditions: - BARRIER CLOSED the light is off - BARRIER IN PAUSE the light is on fixed PLEASE NOTE: the light remains off if the ENERGY SAVING function is enabled and automatic closure is deactivated - BARRIER IN OPENING the light blinks slowly (2Hz) - BARRIER IN CLOSING the light blinks fast (4Hz)			
SEM		Integrated traffic light function This function must be enabled from the SP.R menu. For the detail on the various options, read chapter 12	Grn.L	Grn.L	
	Grn.L	Green light only			
	PEd.L	Pedestrian traffic light			
	A.o'W	Alternating one-way system			
	rd.Gr	Green and red light			
	rEd.L	Red light only			

PARAMETER	VALUE	DESCRIPTION	DEFAULT NUUR4	DEFAULT NUUR6	MEMO
LP.PA		Flashing lamp in pause	no	no	
	no	Function disabled			
	Si	The flashing lamp works also during the pause time (barrier opened with active automatic closing)			
StArE		Function of input START1 and START2 This menu allows choosing the mode of operation of the input START1 and START2	StARn	StARn	
	StARn	Standard mode			
	no	The Start input commands on the terminal strip are disabled. The radio command function depending of the mode StARn			
	in.oU	A command on the START1 input of CHANNEL 1 of the receiver commands opening of the barrier and switch on of the green traffic light inbound. A command on the START2 input of CHANNEL 2 of the receiver controls opening of the barrier and switch on of the green traffic light outbound			
	AP.Ch	Open/Close mode			
	PREs	Dead Man mode			
	oRoL	Clock mode			
StoP		STOP INPUT	no	no	
	no	The input STOP is disabled			
	ProS	The STOP command set the barrier idle: on the next successive command START the barrier resumes the motion in the same direction			
	inuE	The STOP command sets the barrier idle: on the next successive START command makes the barrier resume the motion in the opposite direction to the previous one			
St.nC		ST.NC input function	no	no	
	no	Input not enabled			
	Fire	Input configured for a fire-prevention alarm. If enabled, the barrier opens and automatic closure is disabled			
	PREs	Input configured for presence sensor. If enabled, the barrier opens; when passage is freed, the pause time enables before automatic closure.			
Foto		Photocell input This menu allows programming the behavior in case of participation of the photocell	no	no	
	no	Disabled input (the control unit ignores it)			
	APCh	Input always enabled. The interruption of the photocell during the opening or closing causes the arrest of the barrier. At reset the barrier resumes the opening movement. The interruption when in closed barrier inhibits the opening.			
	CFCh	Input enabled in closing and with closed barrier. The interruption of the photocell during the closing causes the reopening.			
	Ch	Input command enabled only in closing. The interruption of the photocell during the closing causes the reopening. ATTENTION: if this option is chosen, it is necessary to disable the test of photocells			

PARAMETER	VALUE	DESCRIPTION	DEFAULT NUUR4	DEFAULT NUUR6	MEMO
Ft.tE		Test of the photocells	no	no	
	no	Function disabled			
	Si	In order to achieve a safer operation for the user, the unit performs a photocells operational test, before a normal working cycle. If no operational faults are found, the barrier starts moving. Otherwise, it will stand still and the flashing light will stay on for 5 sec. The whole test cycle lasts less than one second			
CoS		Safety ribbon input	no	no	
	no	This menu allows enabling the input for safety ribbon Input disabled (ignored by the control unit)			
	Ch	Input enabled during closure and disabled during opening. The intervention of the safety ribbon cause the reopening of the barrier and the disactivation of any automatic closing			
Co.tE		Test of the safety ribbons	no	no	
	no	This menu allows setting the method of control of the safety ribbons working Test disabled			
	rESi	Test enabled for conductive rubber safety ribbons			
	Foto	Test enabled for optical safety ribbons			
SEn.u		Speed sensor	4	4	
	0 - 7	This menu allows adjustment of the sensitivity used to detect if the barrier is blocked by an obstacle. If set to 0 the obstacle is only detected when the barrier is stopped. When the sensor intervenes, the barrier stops and is operated in the reverse direction for 3 seconds to remove the obstacle. The next start command restarts the movement in the previous direction			
SYnE		MASTER/SLAVE operation of the barrier for installations with 2 barriers	no	no	
	no	Single barrier			
	MAS	MASTER barrier - operation with 2 barriers			
	SLAV	SLAVE barrier - operation with 2 barriers			
Eu.di		Display of the events	Si	Si	
		If this function is enabled, every time that an event changes the normal operation of the gate (coming into action of a safety, control by user, etc.) the display shows a message indicating the cause.			
	Si	Function activated			
	no	Function deactivated			
FinE		End of Programming	no	no	
		This menu allows to finish the programming (both default and personalized) saving the modified data into memory			
	no	Do not quit the programming			
	Si	End of programming			

14 - TESTING AND COMMISSIONING

These are the most important phases of the automation's construction, as they ensure maximum safety of the system. The test can also be used to periodically verify the devices making up the automation.

⚠ Testing and commissioning of the automation must be performed by skilled and qualified personnel, who are responsible for the tests required to verify the solutions adopted according to the risks present, and for ensuring that all legal provisions, standards and regulations are met, in particular all the requirements of the EN 12445 standard, which defines the test methods for checking gate automations.

The additional devices must undergo specific testing, both in terms of their functions and their proper interaction with the control unit. Refer to the instruction manuals of the individual devices.

14.1 - TESTING

To run the test:

1. verify that all the instructions stated in the "GENERAL SAFETY WARNINGS AND PRECAUTIONS" chapter have been strictly observed
2. check that the boom is correctly balanced (see paragraph " Boom balancing")
3. check that the manual unlocking device works properly (see paragraph "Manually unlocking and locking the gearmotor")
4. using the control devices (transmitter, control push-button, key selector, etc.), test the boom opening, closing and stopping phases, ensuring that the movement matches the specifications. Several tests should be conducted to assess the boom's movement and to check for any assembly or adjustment defects or any particular points of friction.

NOTE: If the duration of the maneuver is not correct with respect to the limit switches, make a fine adjustment of the stroke using the parameter **L.RdJ**

5. verify the correct operation of all the safety devices present, one-by-one (photocells, sensitive edges, etc.) whenever a device intervenes, the "OK" LED on the control unit will emit 2 quicker flashes to confirm the recognition
6. verify the correct operation of the photocells in the following way:
 - depending on whether one or two pairs of photocells have been installed, one or two blocks of rigid material (e.g. wooden panels) are required, measuring 70x30x20 cm. Each block must have three sides of reflective material (e.g. mirror or glossy white paint), one for each dimension, and three sides of opaque material (e.g. matt black paint). To test the photocells positioned 50 cm above the ground, the block must be placed on the ground, or raised to 50 cm when testing photocells positioned 1 m above the ground
 - if the test is on a pair of photocells, the testing block must be placed directly under the centre of the boom with the 20 cm sides facing the photocells and moved along the entire length of the boom

29

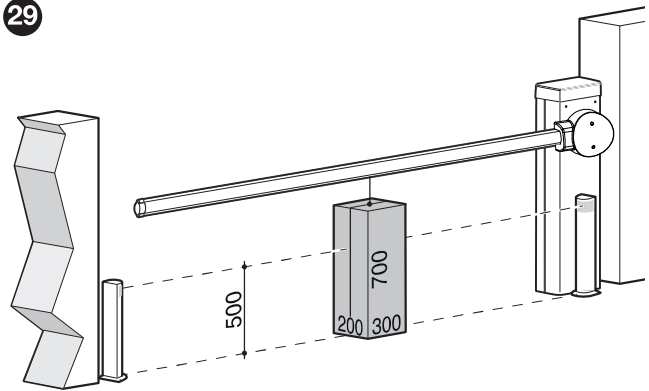

- if the test is on two pairs of photocells, the test must first be performed individually for each pair of photocells using one testing block and then repeated using two testing blocks; each testing block must be positioned laterally in relation to the centre of the boom, at a distance of 15 cm and then moved along the entire length of the boom

30

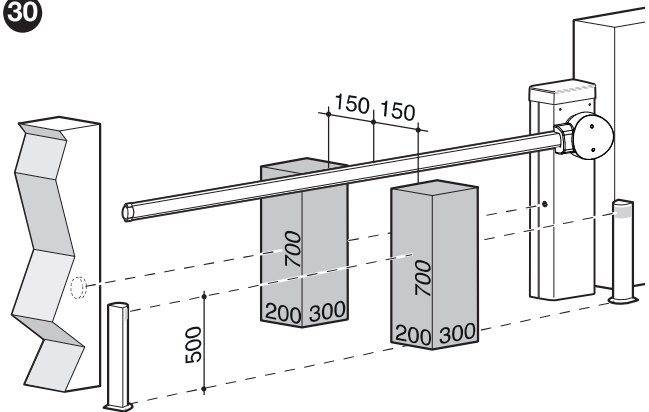

- during these tests, the testing block must be detected by the photocells in any position it lies along the entire length of the boom
7. check that there are no interferences between the photocells and other devices:
 - block the line of sight between the pair of photocells with a cylinder (diameter 5 cm, length 30 cm), by moving it close to the TX photocell first then next to the RX photocell and then at the mid-point between the two

31

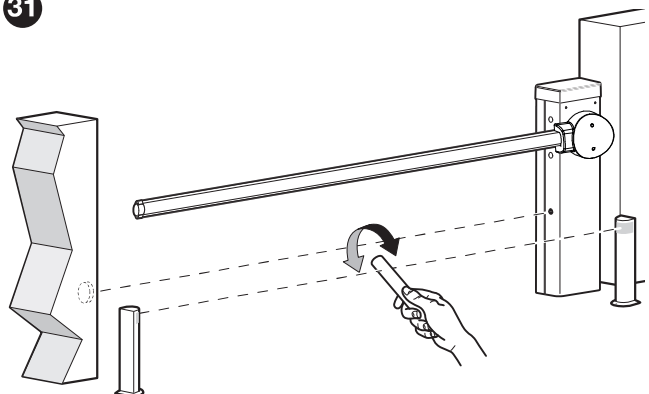

- check that the device intervenes in all cases, switching from the active to the alarm status and vice-versa
- check that it triggers the intended action in the control unit (e.g. a reversal of the movement during the closing manoeuvre)

8. check on the safeguard against the lifting hazard: in automations with vertical movement it is necessary to verify that there is no lifting hazard. This test can be carried out in the following way:
 - hang a 20 kg load (e.g. a sand bag) midway along the boom's length
 - send an opening command and check that during the manoeuvre the boom does not exceed a height of 50 cm above its closed position
 - if the boom exceeds this height, the motor force must be reduced (refer to the chapter "PROGRAMMING")
9. if potentially dangerous situations due to the boom's movement have been prevented by limiting the impact force, the latter must be measured according to the EN 12445 standard and, if the "motor force" control is used to aid the system in reducing the impact force, it is necessary to test various adjustments to find the one that gives the best results
10. checking the efficiency of the unlocking system:
 - put the boom in the closed position and manually unlock it (see paragraph "Manually unlocking and locking the gearmotor")
 - verify that this occurs smoothly
 - verify that the manual force to move the boom during the opening phase does not exceed 200 N (roughly 20 kg)
 - the force is measured perpendicularly to the boom at 1 m from the rotation axis
11. verification of the power supply disconnection system: operate the power disconnection device and disconnect any available back-up batteries; check that all the LEDs on the control unit are OFF and that the boom remains stationary when a command is sent. Check the efficiency of the locking system to prevent any unintentional or unauthorised connection.

14.2 - COMMISSIONING

⚠ Commissioning can only be performed after all testing phases have been successfully completed.

⚠ Before commissioning the automation, ensure that the owner is properly informed of all residual risks and hazards.

⚠ The gate cannot be commissioned partially or under "temporary" conditions.

To commission the automation:

1. compile the automation's technical file, which must include the following documents: overall drawing of the automation, wiring diagram, risk assessment and relative solutions adopted, the manufacturer's declaration of conformity for all devices used and the declaration of conformity compiled by the installer
2. affix a permanent label or sign on the cubicle specifying the operations for unlocking the gate and manoeuvring it manually "Figure 32"

32

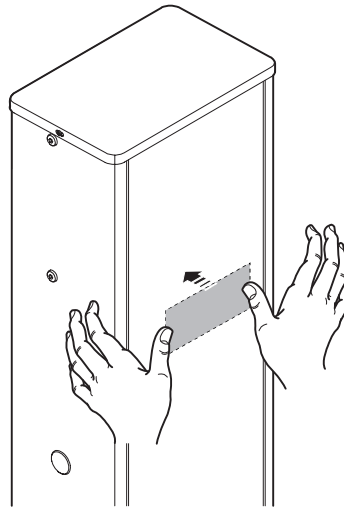

3. affix a data plate to the cubicle specifying at least the following data: type of automation, name and address of the manufacturer (responsible for commissioning), serial number, year of manufacture and CE mark
4. compile the declaration of conformity of the automation and hand it to the owner of the automation
5. compile the User Manual of the automation and hand it to the owner of the automation
6. compile and provide the owner with the automation's "Maintenance schedule", containing the maintenance instructions for all the automation's devices.

15 - FURTHER INFORMATION (Accessories)

15.1 - PLUG IN RECEIVER

KB24 control unit is suitable for plugging in MR receiver.

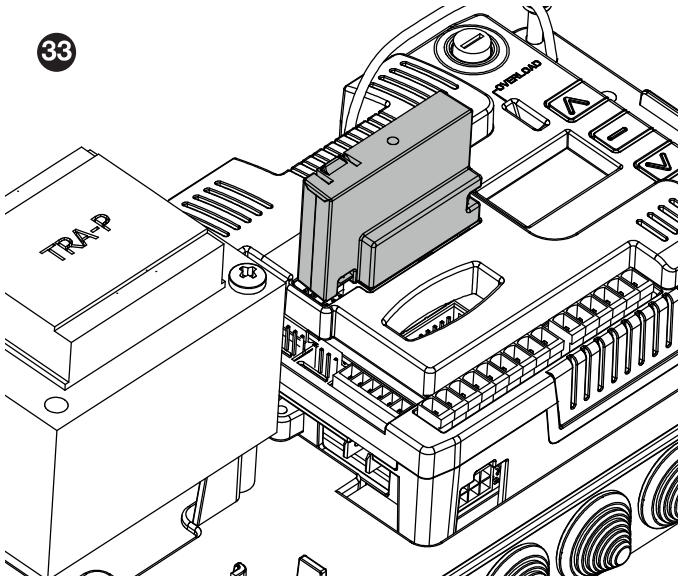

⚠ WARNING: Pay attention to the way you connect the removable modules.

MR module receiver is provided with 4 channels and each of them is suitable for a command of KB24 control unit:

- CHANNEL 1 → START1
- CHANNEL 2 → START2
- CHANNEL 3 → STOP
- CHANNEL 4 → COURTESY LIGHT

NOTE: Before programming 4 channels and function logics read carefully the instructions of MR.

15.2 - CONNECTING AND INSTALLING THE BACKUP BATTERY

⚠ The electrical connection of the battery to the control unit must be made only after completing all the installation and programming stages, as the battery is an emergency power supply.

⚠ Before installing a back-up battery, disconnect the power supply to the control unit.

To install and connect the battery:

1. install the battery holding bracket
2. position the battery on the bracket and fasten it with the tie

34

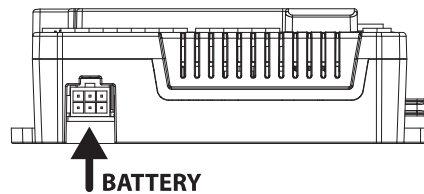
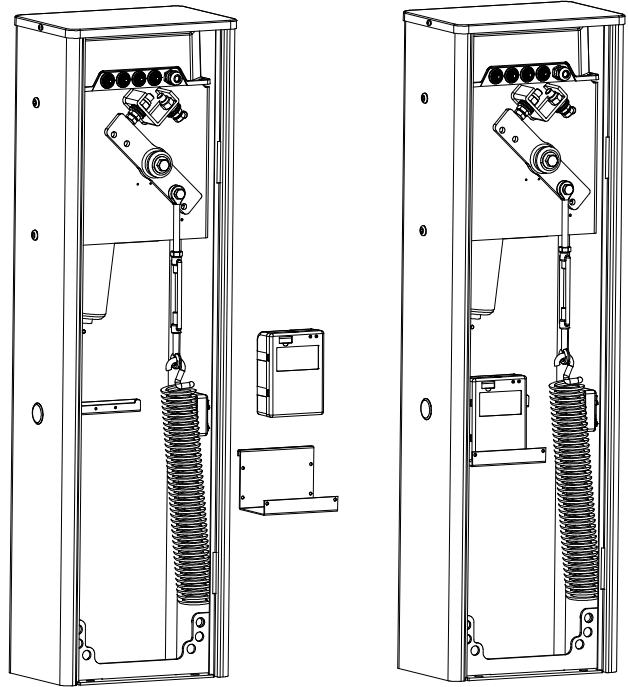

3. connect the battery to the dedicated connector

15.3 - BOOM LIGHTS CONNECTION (OPTIONAL ACCESSORY)

For installation:

1. bring the boom to the vertical position
2. unscrew the screws fastening the barrier cover and the support
3. temporarily remove the boom

35

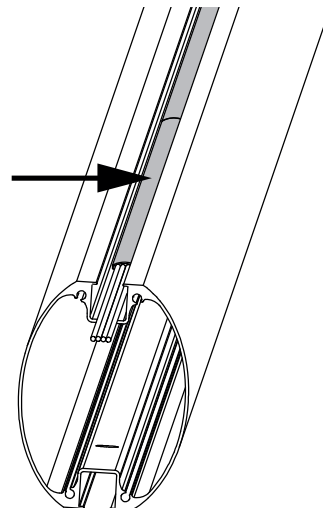

4. apply the adhesive led strip on the boom and insert it in the slot

⚠ ATTENTION: if the led strip must be shortened, cut where the symbol is shown



5. insert the wiring using the hole on the cabinet

36 NUUR 4

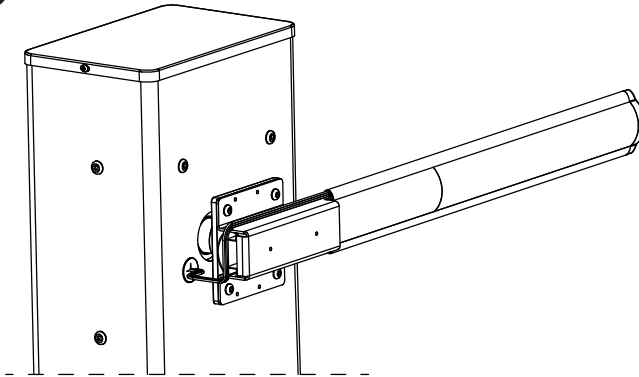

NUUR 6

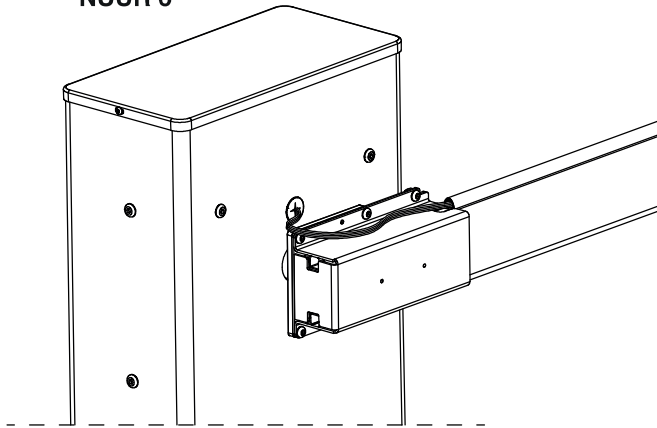

⚠ leave a bit of cable inside the boom support, so that the boom can be rotated without causing any tension along the cable.

6. connect the lights cable to the SYNCLUX module (for installation, follow the specific instructions supplied with the module)
7. fasten the cable inside the cabinet using the ties
8. assemble the bumper rubber as described in chapter 3.8
9. insert the boom and fasten it with the support and cover

15.4 - PHOTOCELLS

You can install one of the photocells (code 13S017) inside the barrier mechanism in the space provided.

To perform the installation:

1. remove the card of the photocell (A) from its box by levering with a screwdriver. Take care not to damage the electrical components.
2. open the box prepared for the photocells (B) provided

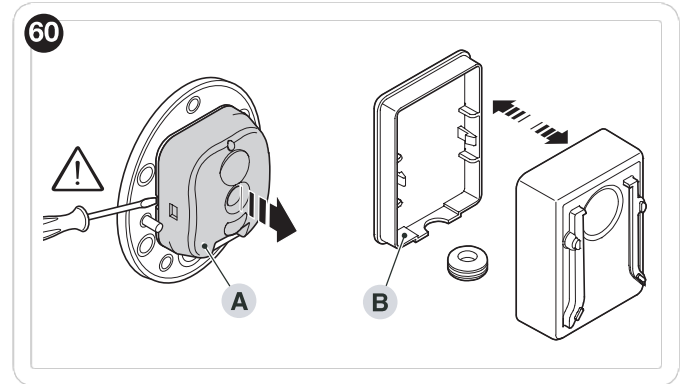

3. remove the RX electronics and insert it into the transparent shell supplied
4. secure the card into the back of the box
5. drill through the rubber part (C) prepared for passing the cables
6. pass the photocell connection cable through the rubber part
7. connect it to the photocell card

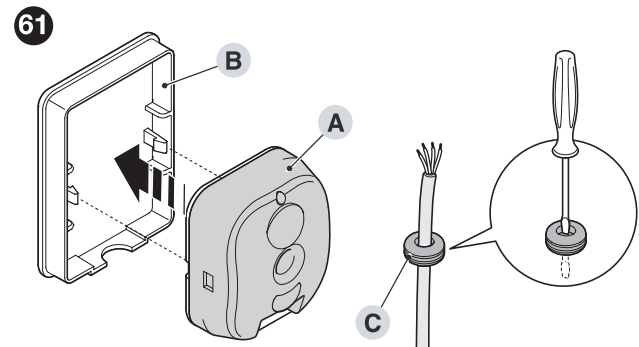

8. close the box with the cover, blocking the rubber part inside its housing
9. hook the box over the lens (D) inside the cabinet, sliding it from the top downwards

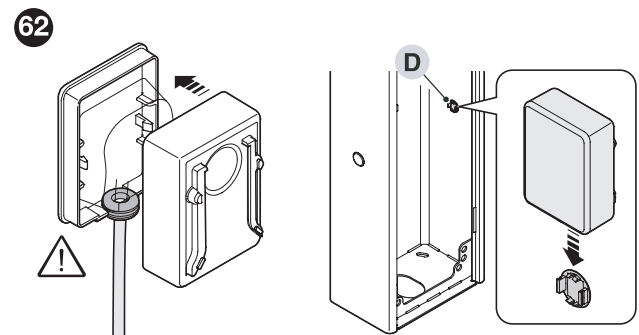

⚠ For further information, refer to the instruction manual for the photocells.

16 - TIMER SETTING

With the **-EEM** menu, you can adjust the time of the RTC on the control unit and set up to 8 timers to open and/or close the gate at the preset times, with weekly programming.

16.1 - CLOCK SETTING - SEt

To use the timing functions, you should set the clock on the control unit.

Enter the **SEt** menu and set the year, month, day and time using the keys **↑**, **↓** and **OK**:

- Y 20** → indicates the year 2020
- m 11** → indicates the month 11 (November)
- d 15** → indicates the day of the month
- h 11** → indicates the time
- m 14** → indicates the minutes

Having set the above parameters, you can enable the **day light saving** function which allows the clock on the control unit to remain aligned with the correct time during the changes between the standard/ daylight saving time.

NOTE: setting the **dLS.Y** parameter, the automatic time change on the given dates will be enabled.

Having terminated the settings, press **OK** to confirm and save the new parameters.

16.2 - TIMINGS SETTING - EEM

You can set up to 8 timings and a different command can be enabled for each of these.

1. Enter the **EEM** menu and select the desired timer using the keys **↑**, **↓** and **OK** (see diagram from point 2 onwards).
2. Select the desired function to associate with the timer.

The functions available for the timers are as follows:

- C h U**: execute a closure command at the time set.
- o r o L**: allows you to set a time for automatic opening and one for automatic closure. Between the opening time and closure time, you can control the gate opening or closure using commands.
- P r o**: sets a time for automatic opening and one for automatic closure. Between the opening and closure time, all the commands are disabled.
This allows you to be sure that the barrier within these times stays open.

3. Set the times of the timer (*)

(*) Setting of timer times

1. The display shows the opening time currently set (diagram 2 panel A) : the hours flash
NOTE: the top arrow beside the seconds is on to indicate the opening time is being programmed
2. Adjust the time using the keys **↑ ↓** and press **OK** to confirm: the minutes flash
3. Adjust the time using the keys **↑ ↓** and press **OK** to confirm
4. The display shows the closure time currently set (diagram 2 panel B) : the hours flash
NOTE: the bottom arrow beside the seconds is on to indicate the closure time is being programmed
5. Adjust the time using the keys **↑ ↓** and press **OK** to confirm: the minutes flash
6. Adjust the minutes using the keys **↑ ↓** and press **OK** to confirm: the display shows the day of the week
(**m** = Monday, **t u** = Tuesday, **w** = Wednesday, **t h** = Thursday, **F r** = Friday, **S a** = Saturday, **S u** = Sunday) displaying if the function on that day is enabled (**Y**) or disabled (**n**)
7. Set the desired parameter for each day then select **ESC** to save and exit; the display shows the timer just set (e.g. **E m . 1**)
8. Select **SAVE** to save the settings: the display shows the control panel

NOTE: when a timer is saved, it will be identified on the display by the flashing cursor **▶** to the side (e.g. **E m . 2 ▶**)

CANCELLING PROGRAMMED TIMERS

To delete programming of a timer, proceed as follows:

1. Enter the **EEM** menu and select the desired timer using the keys **↑**, **↓** and **OK** (see diagram from point 2 onwards).
2. The programmed timer is identified on the display by the flashing cursor **▶** to the side (e.g. **E m . 2 ▶**)
3. Select the **CRnC** function: the display shows the timer which has just been cancelled (e.g. **E m . 1**)
4. Select **SAVE** to save the settings: the display shows the control panel

16.3 - SUSPENDING TIMERS - SUSP

Using the **SUSP** parameter, you can suspend the timers for a period which can be selected ranging from a minimum of 6 hours to a week. In this period, any programmed timers will be considered. This function is very useful for the end client if he or she wants to suspend openings/closures previously programmed without however deleting them.

1. Enter the **SUSP** menu and select the period for which you want to suspend the timers:
 - 6 h** → 6 hours
 - 12 h g** → 12 hours
 - 1. dAY** → 1 day
 - 2. dAY** → 2 days
 - 3. dAY** → 3 days
 - WEE** → 1 week
2. Select **OK** to confirm: the display shows the control panel

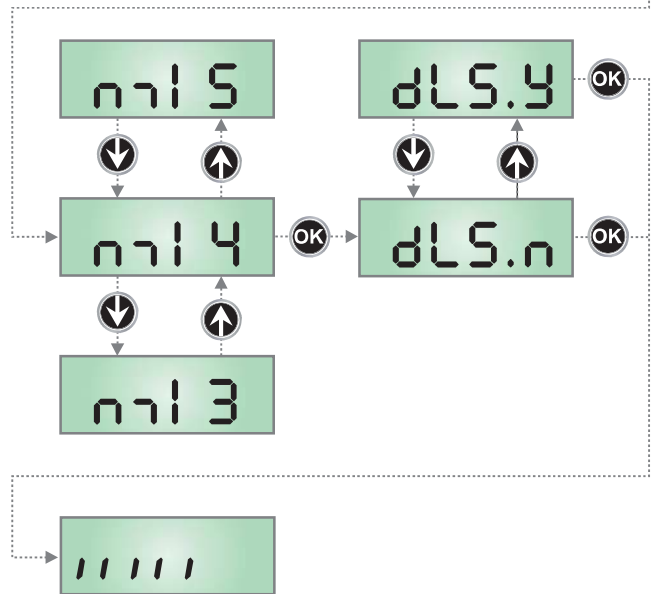
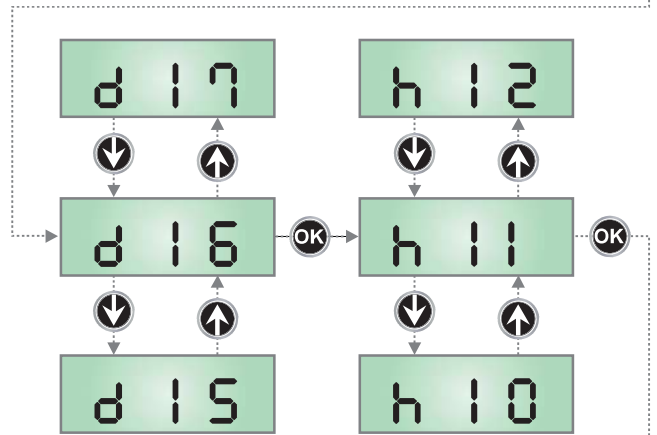
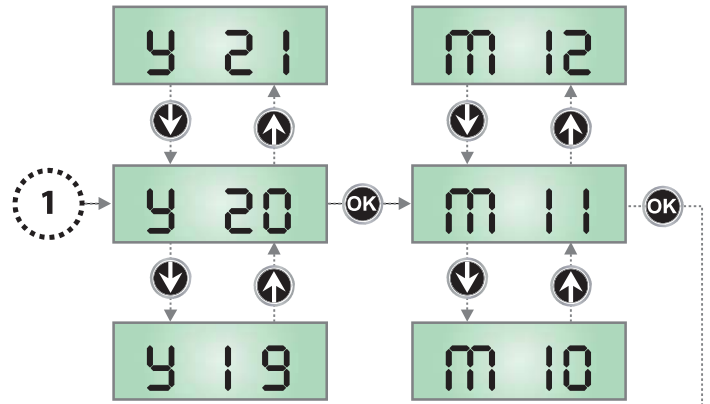
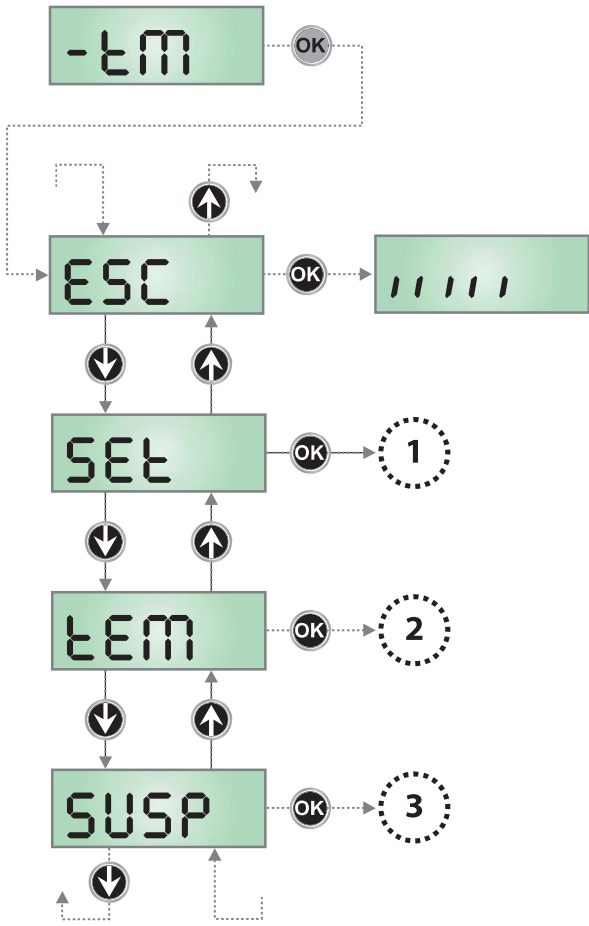

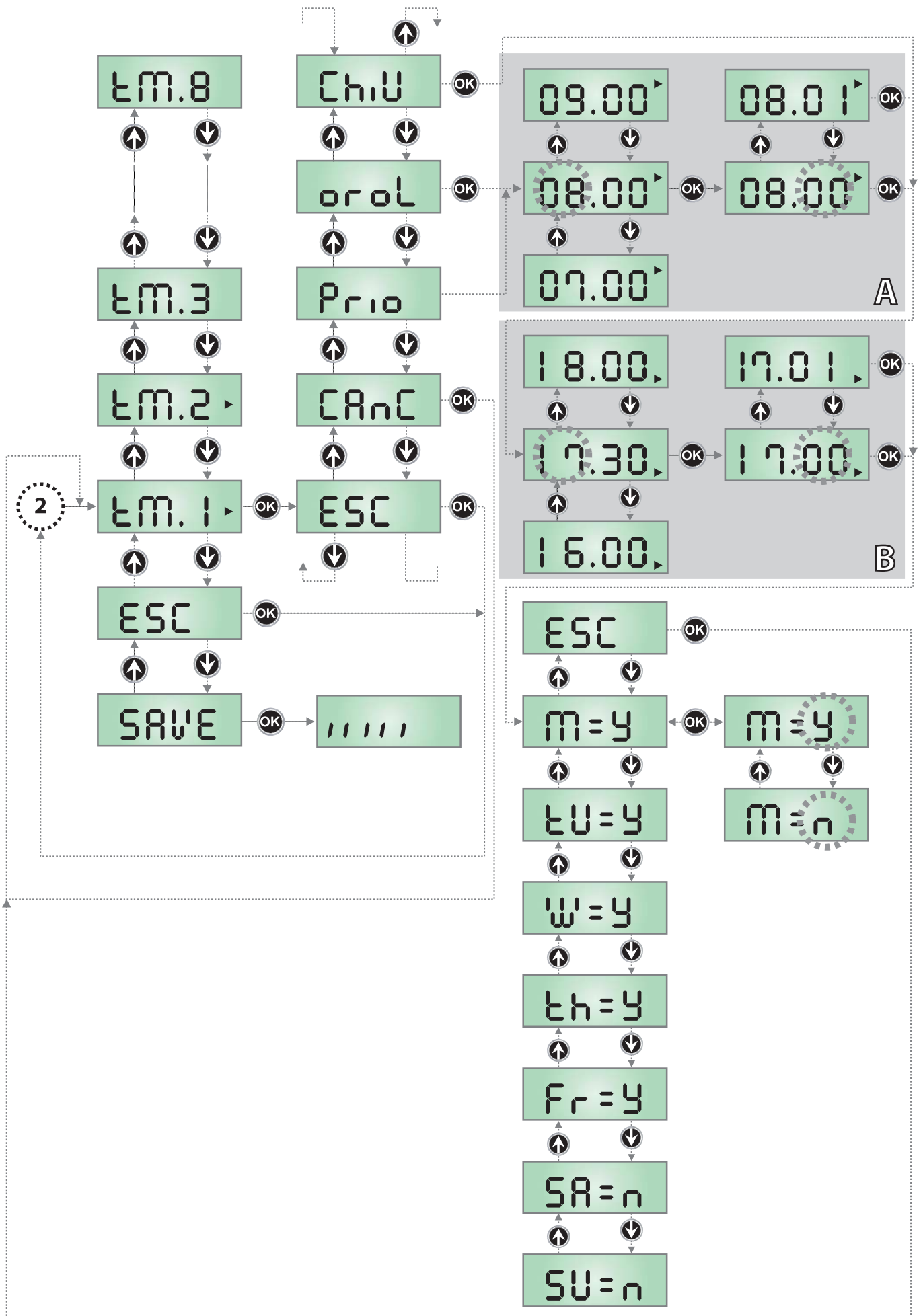

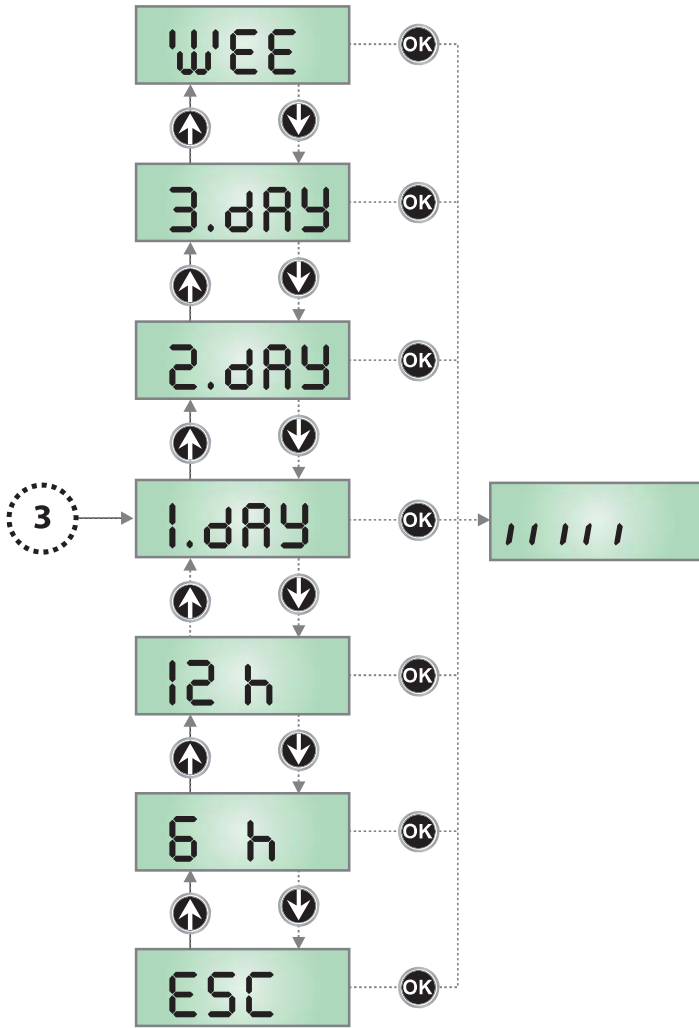

17 - TRAFFIC LIGHT FUNCTION

A traffic light can be connected on the control unit to indicate to the vehicle when it can go through the opening, or two traffic lights to adjust the entry direction.

The traffic light function must be enabled on the **SPIR** menu, therefore the **SEM** menu allows you to choose which function you want to be executed. For some functions, you must use other outputs of the control unit; in this case, the functionalities are lost of the electromagnet and the courtesy lights.

For connection of the traffic light, you can use the Synclux optional board; if you want to add this board, or if already used for the lights on the boom, you can use the output of the low voltage lights to connect the traffic light directly to the control unit, giving up the other functions on this output.

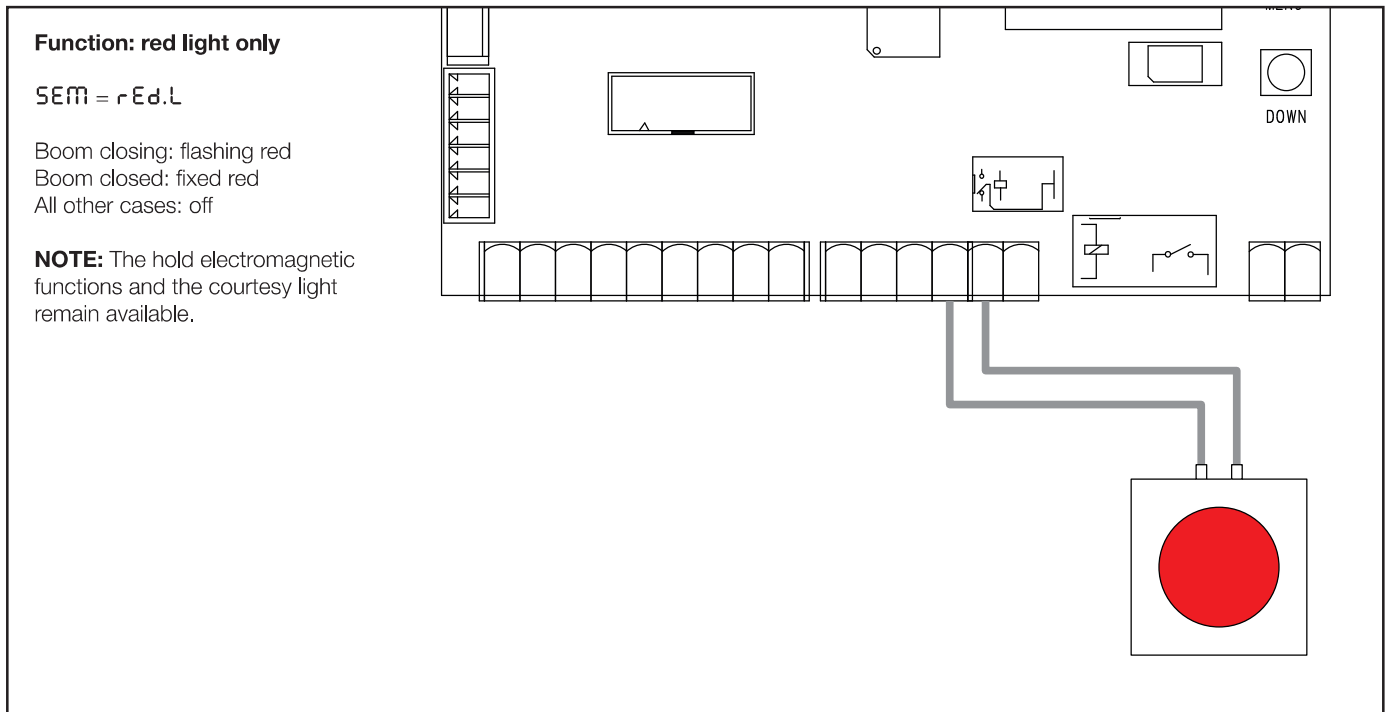
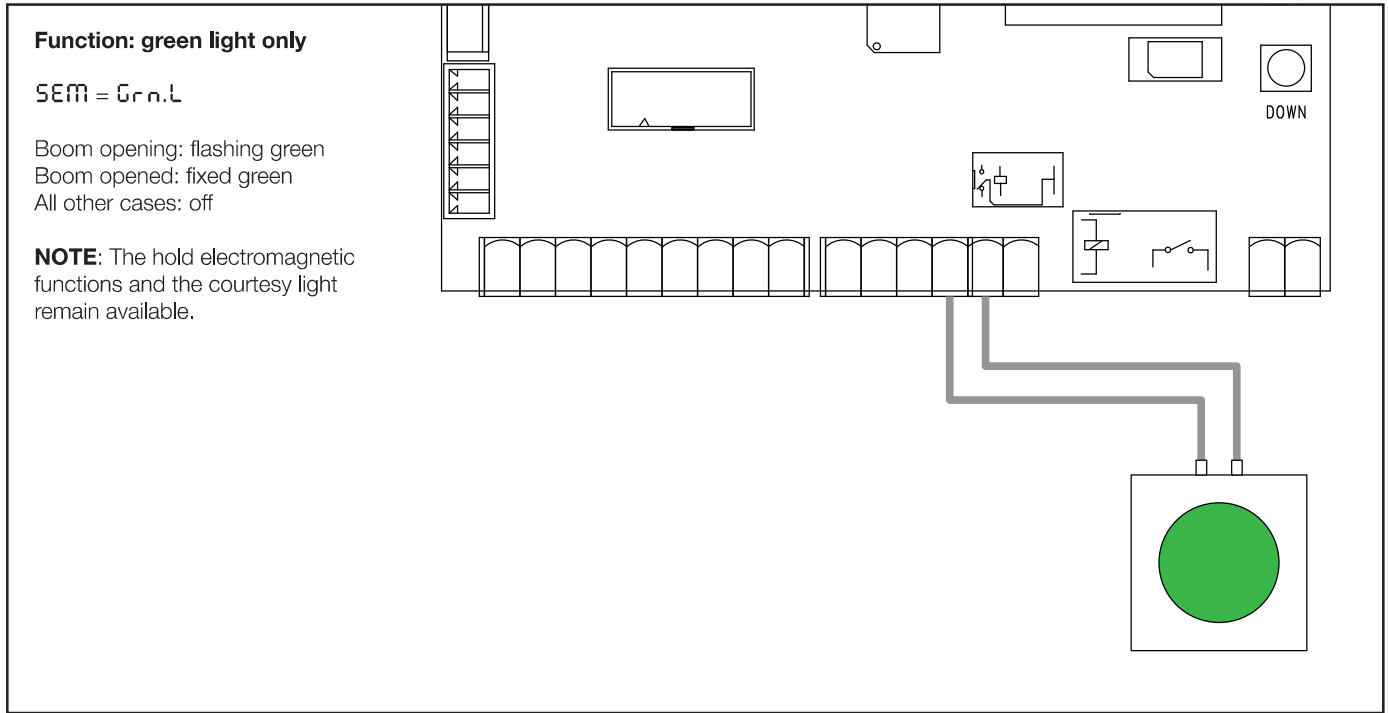

Function: one-way traffic light

SEM = r d. G n

- Boom opening: flashing green
- Boom opened: fixed green
- Boom closing: flashing red
- Boom closed: fixed red

NOTE: The courtesy light function remains available.

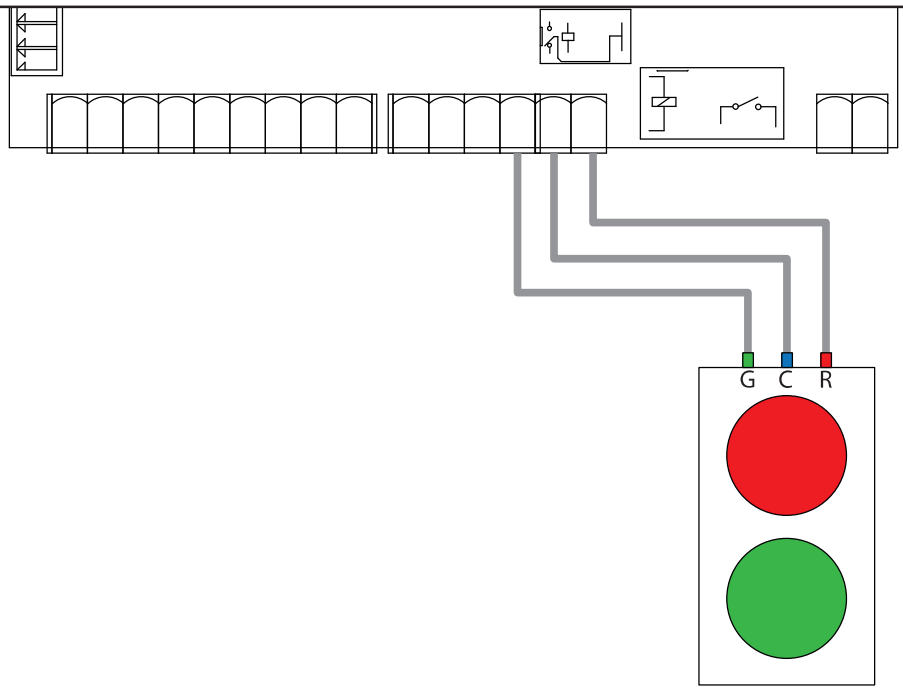

Function: Alternating one-way system

SEM = R. o' W

- Boom opening or opened: green in the enabled direction, red in the other
- Boom closing or closed: red in both directions

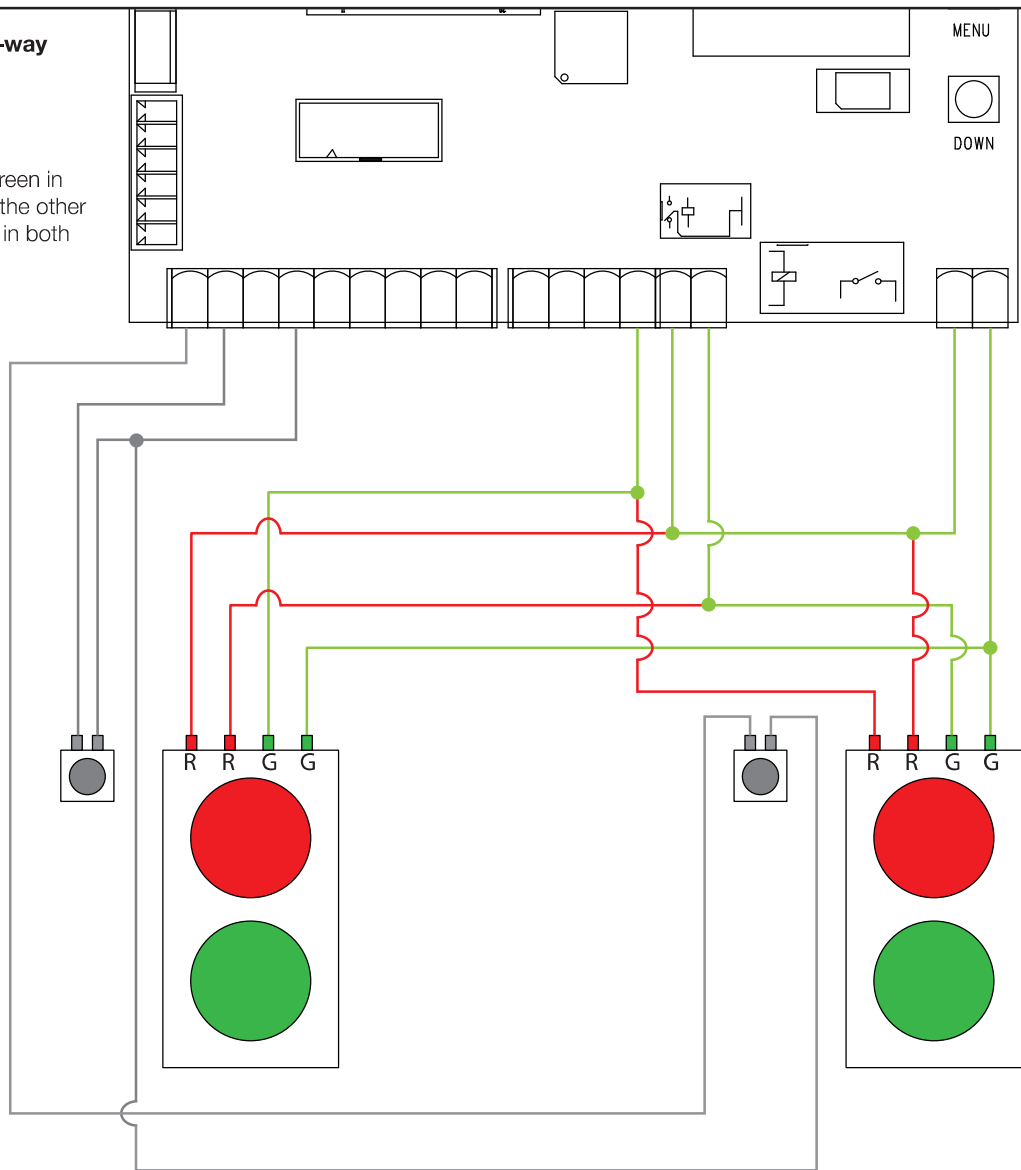

Function: Pedestrian Traffic Light

SEM = PE d.L

Boom closed: green inside, red outside
Boom open: red inside, green outside
Boom in motion, red on both sides

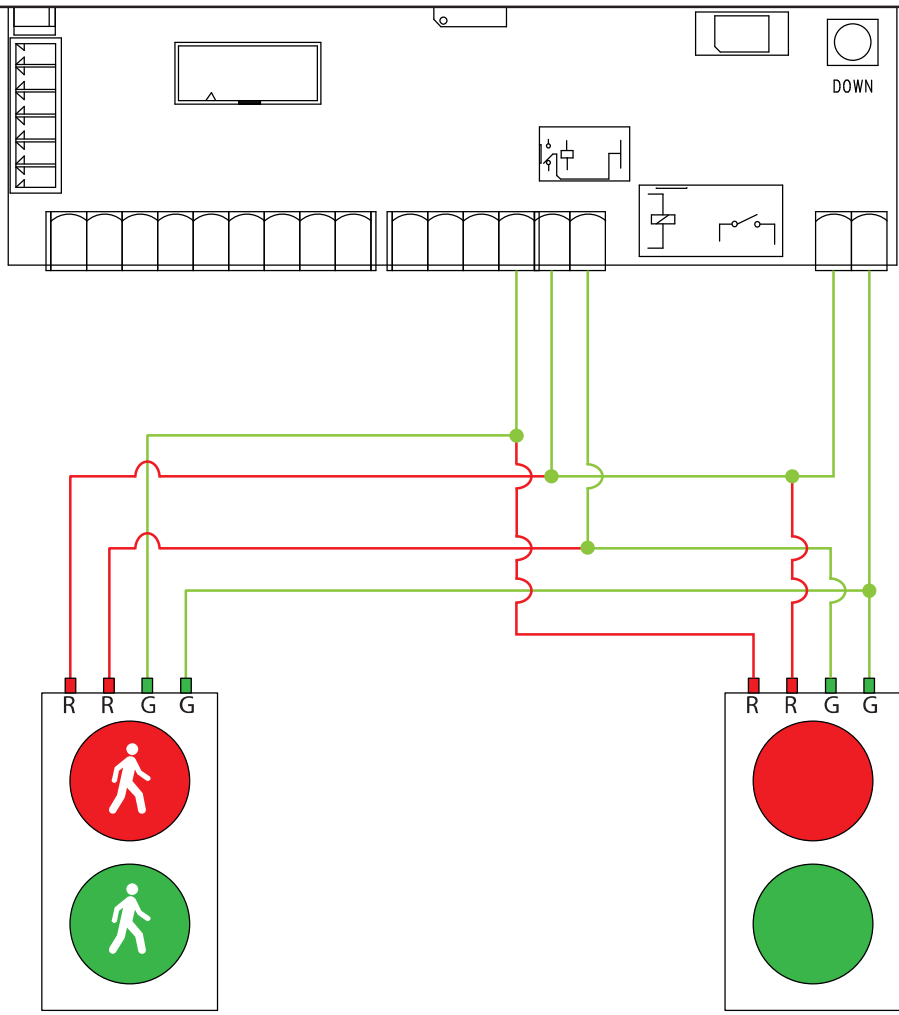

18 - OPERATION DEFECTS

This paragraph shows some possible operation defects, along with their cause and applicable remedy.

Some anomalies are signalled using a message on the display, others with flashing signs or the leds assembled on the control unit.

NOTE: following an anomaly, the error message displayed on the display stays active until the control unit receives a START command or the MENU key is pressed.

DISPLAYING	DESCRIPTION	SOLUTION
<p>MAINS led does not switch on</p> <p>NOTE: the led is seen through the ventilation slots of the rear of the container</p>	<p>It means that there is no voltage on control unit card.</p> <p>NOTE: the led is never switched on if the motor is battery operated</p>	<ol style="list-style-type: none"> 1. Before acting on the control unit, disconnect through the disconnecting switch on the power line and remove the power supply terminal. 2. Be sure that there is no voltage break upstream the control unit. 3. Check whether the fuse is burnt-out, if so replace it with same value.
OVERLOAD led is on	It means that there is an overload on accessory power supply.	<ol style="list-style-type: none"> 1. Remove the extractable part containing terminals J1 - J9 and Z1 - Z6 . OVERLOAD led will switch off. 2. Remove the overload cause. 3. Reinsert the terminal board extractable part and check that this led is not on again
OVERLOAD led is on and the display shows oF.L.	It means there is no power available for the motor and accessories	Check the transformer connections. If the transformer is connected correctly, send the control panel and transformer for repair.
Too long pre-blinking	When a Start command is given and the blinker switches on immediately but the gate is late in opening	It means that the setup cycle count down expired and the control unit shows that service is required (chapter 12)
The display shows F o t o	When a command is given to start, the boom does not lift (or does not close again). It means the intervention of the photocell prevents barrier manoeuvre.	<ol style="list-style-type: none"> 1. Check there are no obstacles between the photocells. 2. Ensure the photocells are powered and working: interrupt the ray and check that the photocell segment on the display changes position
The display shows o s	When a command is given to start, the boom does not lift (or does not close again). It means the intervention of the rib prevents barrier manoeuvre.	<ol style="list-style-type: none"> 1. Check the safety edge is not pressed or damaged. 2. Ensure safety edge is connected correctly: activate the safety edge and check the safety edge section on the display changes position.
The display shows S t o p	When a start command is given, the barrier does not open. It means that STOP input prevents gate movement.	<ol style="list-style-type: none"> 1. Check the STOP button is not pressed. 2. Ensure the button is working correctly
The display shows F i r e	The barrier is raised without receiving any control and cannot close again. It means the fire alarm is on.	Check the signalling causes and, if necessary, reset operation.
The display shows P r e s	The barrier has raised and the control unit refuses the closure commands. It means the presence sensor is enabled.	Remove the cause of sensor enabling. If no object or person engages the presence sensor, it means the sensor is faulty or not aligned.
The display shows E r r 2	It means that MOSFET test failed	Contact the V2 technical assistance service to send the control unit for repair
The display shows E r r 3	When a start command is given, the barrier does not open. It means that the photocell test failed.	<ol style="list-style-type: none"> 1. Be sure that no obstacle interrupted the photocell beam when the Start command was given. 2. Be sure that photocells, as enabled by their relevant menus, have been installed actually. 3. Be sure that photocells are powered and working: interrupt the ray and check that the photocell segment on the display changes position. 4. Ensure the photocells are connected correctly, as shown in the chapter 5.5

DISPLAYING	DESCRIPTION	SOLUTION
The display shows Err5	When a start command is given, the barrier does not open. It means that the test of the safety edges failed.	<ol style="list-style-type: none"> 1. Make sure that the menu relative to the test of the facets for cables (Co.EE) is configured correctly. 2. Make sure that the safety edges enabled by menu are actually installed. 3. Check the safety edges are correctly connected as indicated in chapter 5.6.
The display shows Err6	When a start command is given, the barrier does not rise. It means that the measurement circuit test has failed of the motor current.	Contact the V2 technical assistance service to send the control unit for repair
The display shows Err7	Encoder error	Check the connection of the encoder
The display shows Err8	When executing a self-learning function the control is refused. It means that the setting of the control unit is not compatible with the requested function	Check the Start inputs are enabled in standard mode (SErE menu set on SErN)
The display shows Err9	It means that programming was locked by means of the programming lock key CL1+ (code 161213).	To change the settings it is necessary to insert in the connector of the ADI interface the same key used to activate the programming lock, and unlock the device.
The display shows Err11	When a start command is given, the barrier does not rise. It means that motor thermal protection has intervened.	Wait for the motor to cool.
The display shows Err12	During manoeuvre, the barrier stops. It means the control electronics of the motor have reached too high a temperature and proceeding with the manoeuvre could cause serious risk for the intactness of the components.	The control unit will start working again when the circuit has cooled.
The display shows Err13	The self-diagnosis circuit has detected a malfunction that prevents the safe operation of the automation	Contact the V2 technical assistance service to send the control unit for repair
The display shows Err14	The self-diagnosis circuit has detected an error in the configuration parameter table	Enter the configuration menu, carefully check all the parameters and correct any errors. If the error persists, contact the V2 technical assistance service to send the control unit for repair
The display shows Err15	The duty cycle limit has been exceeded	The control unit will return to normal operation after a forced pause. In this situation it is still possible to activate the automation in EMERGENCY DEAD MAN OPERATION mode (chapter 11)
The display shows Lim	When a start command is given, the barrier does not rise. It means a timer was programmed inside the control unit, which prevents barrier enabling at that time.	Wait for the control unit to become available again.
The display shows ScEn	When a start command is given, the barrier does not rise. It means an App-controlled situation is in progress.	Wait for the control unit to be available again, or shut-off execution of the App situation.

INSTRUCTIONS AND WARNINGS FOR THE USER

Before using the automation for the first time, ask the installer to explain the origin of any residual risks and take a few minutes to read this instruction manual and warnings for the user given to you by the installer. Store the manual for future reference and hand it to the new owner when transferring the automation.



WARNING!

Your automation is a machine that faithfully executes commands imparted by the user. Negligence and improper use may lead to dangerous situations:

- do not manoeuvre the gate if there are people, animals or objects within its range of operation
- it is strictly forbidden to touch parts of the automation while the boom is moving
- the photocells are not a safety device but only an auxiliary aid to safety. They are built using highly reliable technology but, in extreme conditions, may malfunction or even become defective. In certain cases, the defect may not be clearly evident. For these reasons, it is important to follow all the instructions given in this manual when using the automation
- periodically check that the photocells work properly.



IT IS STRICTLY FORBIDDEN to transit while the boom is moving! Transit is allowed only if the boom is fully open and stationary.



CHILDREN

An automation system guarantees a high degree of safety. With its detection systems, it can control and guarantee the gate's movement in the presence of people or objects. It is nonetheless advisable to forbid children from playing near the automation and not to leave remote controls near them to prevent any unwanted activation of the system.

The automation is not a toy!

The product is not intended for use by persons, including children, with limited physical, sensory or mental capacities, or who lack experience or knowledge, unless supervised or trained in the use of the product by a person responsible for their safety.

Anomalies: if the automation shows any signs of anomalous behaviour, disconnect the power supply to the system and manually unlock the motor (see instructions at the end of the chapter) to manoeuvre the boom manually. Do not attempt any repairs personally but contact your trusted installer.



Do not modify the system or the programming and adjustment parameters of the control unit: your installer is exclusively responsible for these operations.

Failure or lack of power supply: while waiting for the installer to intervene or the electricity to be restored, if the system is not equipped with back-up batteries, the automation can nonetheless be used by manually unlocking the motor (consult the instructions at the end of the chapter) and moving the boom manually.

Safety devices out of order: the automation can also be used when one or more safety devices are defective or out of order. The gate can be operated in the "Hold-to-run" mode in the following way:

1. submit a control to move the boom, using a transmitter or key selector, etc. If everything works properly, the boom will move normally, otherwise it will stay in position
2. in this case, within 3 seconds press the control again and hold it down
3. after roughly 2 seconds, the boom will complete the requested manoeuvre in "Hold-to-run" mode, in other words, it will continue to move so long as the control is held down.



If the safety devices are out of order, have the system repaired as soon as possible by a qualified technician.

The test, periodic maintenance and any repairs must be documented by the person carrying out the work and the documents must be stored by the owner of the automation. The only interventions the user may carry out periodically include cleaning of the photocell glass components (use a soft and slightly damp cloth) and removing any leaves or stones that may obstruct the automation.



Before carrying out any maintenance operations, the user of the automation must manually unlock the motor to prevent anyone from accidentally triggering the boom's movement (consult the instructions at the end of the chapter).

Maintenance: in order to ensure constant levels of safety and the longest useful life for the automation, routine maintenance must be carried out (at least every 6 months).



Only qualified personnel is authorised to carry out checks, maintenance operations and repairs.

Disposal: at the end of its useful life, the automation must be dismantled by qualified personnel and the materials must be recycled or disposed of in compliance with the local regulations in force.

Replacing the remote control battery: if your remote control appears to be working poorly after some time, or stops working altogether, it may simply depend on flat batteries (depending on how much the device is used, the batteries may last from several months to over a year). You will notice this by the fact that the indicator light signalling the transmission fails to light up, is weak or lights up only for a short time. Before contacting the installer, try replacing the battery with that of another transmitter that works properly: if the anomaly is resolved, simply replace the flat battery with one of the same type.

Unlocking and manual movement

To unlock the device:

1. turn the key slot cover
2. insert the key (A) and turn it towards the left or right

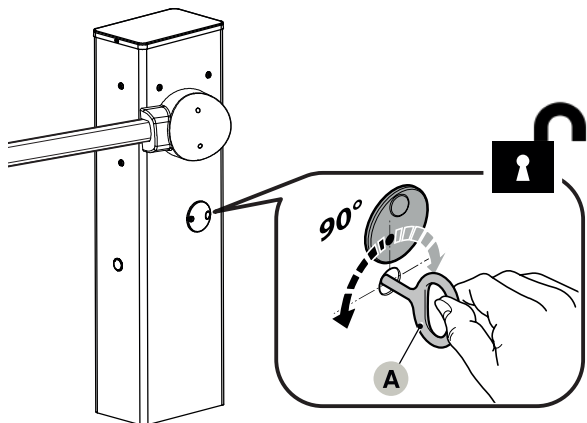

3. at this point, you can manually move the boom to the desired position.

To lock the device:

1. turn the key (A) back to its initial position
2. remove the key
3. turn the key slot cover.

MAINTENANCE SCHEDULE (to be handed to the end user)

 **This maintenance register must be passed on to the new owner of the automation, after having filled in the relevant sections.**

This register must contain a list of all the maintenance activities, repair work and alterations to the automation. The register must be updated every time work is carried out and must be stored carefully so that it is available for any inspections that may be required by the relative authorities.

This "Maintenance register" refers to the following automation:

model NUUR - serial no° - installed on
- at

The following attached documents are part of the Maintenance Register:

- 1) - Maintenance schedule
- 2) -
- 3) -
- 4) -
- 5) -
- 6) -

According to the enclosed document "Maintenance Schedule", maintenance operations must be performed at the following intervals: **every 6 months** or every **50.000 manoeuvre cycles**, depending on the event that occurs first.

MAINTENANCE SCHEDULE

 **Warning! – All maintenance work on this system must be carried out by qualified technical personnel, in full compliance with the safety standards provided for by the laws in force and the safety instructions specified in the "GENERAL SAFETY WARNINGS AND PRECAUTIONS" chapter, at the beginning of this manual.**

In general, this boom gate mechanism does not require special maintenance; however, regular checks over time will ensure system efficiency and correct operation of the safety systems installed. For maintenance of devices added to the boom gate mechanism, follow the provisions laid down in the respective maintenance schedules.

As a general rule, it is advisable to perform a periodic check every 6 months or 50.000 manoeuvres.

Bear in mind that should the spring break, the boom gate will nonetheless conform to the requirement set out in section 4.3.4 of the EN 12604:2000 standard.

 **The boom balancing system must be checked at least 2 times a year, preferably when the seasons change.**

These checks and replacements must be performed at the scheduled maintenance intervals:

1. disconnect all power supplies
2. check for any deterioration of the components which form the barrier mechanism, paying particular attention to corrosion or oxidation of the structural parts; replace any parts that are below the required standard
3. make sure that all screwed connections are properly tightened (especially those of the balancing spring)
4. check that there is no clearance between the balancing lever and the exit shaft. If necessary, fully tighten the central screw

5. lubricate the swivel head of the balancing spring and the lower anchor
6. on versions NUUR6, check the perfect locking between the two boom segments. If necessary, adjust the expansion screws.
7. place the boom in the vertical position and verify that the pitch between the coils of the balancing spring is constant without any deformation
8. unlock and check the correct balancing of the boom and for any obstacles during manual opening and closing
9. relock the boom and run the testing procedure.
10. Verification of the safeguard against the risk of lifting: on automations with vertical movement, it is necessary to check that there is no lifting danger. This test can be carried out as follows: hang a 20 kg load (e.g. a sand bag) halfway along the length of the boom then command an opening manoeuvre and check that during the manoeuvre the boom does not exceed a height of 50 cm above its closed position. If the boom exceeds this height, the motor force must be reduced (refer to the "Programming the control unit" paragraph).
11. If potentially dangerous situations due to the boom's movement have been prevented by limiting the impact force, the latter must be measured according to the EN 12445 standard and, if the "motor force" control is used to aid the system in reducing the impact force, it is necessary to test various adjustments to find the one that gives the best results.
12. Checking the efficiency of the unlocking system: place the boom in the "closed" position and manually unlock the gearmotor (refer to the "Manually unlocking and locking the gearmotor" paragraph), making sure that this occurs without difficulty. Check that the manual force for moving the boom to the "open" position does not exceed 200 N (approximately 20 kg); the force is measured perpendicular to the boom and at 1 m from the axis of rotation. Lastly, check that the manual release key is available near the automation.
13. Check the power supply disconnection system: operate the power disconnection device and disconnect any available back-up batteries; check that all the LEDs on the control unit are OFF and that the boom remains stationary when a command is sent. Check the efficiency of the locking system to prevent any unintentional or unauthorised connection.

